

Всеукраїнський науково-технічний журнал

All-Ukrainian Scientific & Technical Journal

ISSN 2520-6168 (Print)

DOI:10.37128/2520-6168-2024-3

№3 (126)



2024

Machinery
Energetics
Transport
of Agribusiness

ТЕХНІКА
ЕНЕРГЕТИКА
ТРАНСПОРТ АПК



Науковий журнал

**ТЕХНІКА,
ЕНЕРГЕТИКА,
ТРАНСПОРТ АПК**

№ 3 (126) / 2024

м. Вінниця – 2024

Scientific Journal

**Engineering,
Energy, Transport
AIC**

Vol 126, № 3 / 2024

Vinnytsia – 2024

**ТЕХНІКА,
ЕНЕРГЕТИКА,
ТРАНСПОРТ АПК**

Заснований у 1997 році під назвою «Вісник Вінницького державного сільськогосподарського інституту».
Правонаступник видання: Збірник наукових праць Вінницького національного аграрного університету. Серія: Технічні науки.
Свідоцтво про державну реєстрацію засобів масової інформації
КВ № 16644–5116 ПР від 30.04.2010 р.

Науковий журнал «Техніка, енергетика, транспорт АПК» / Редколегія: Токарчук О.А. (головний редактор) та інші. Вінниця, 2024. № 3 (126). С. 1-92.

Друкується за рішенням Вченої ради Вінницького національного аграрного університету (протокол № 6 від 24.12.2024 р.)

Свідоцтво про державну реєстрацію засобів масової інформації №21906-11806 Р від 12.03.2016р.

Журнал «Техніка, енергетика, транспорт АПК» включено до переліку наукових фахових видань України з технічних наук (Категорія «Б», Наказ Міністерства освіти і науки України від 02.07.2020 року №886).

Згідно рішення Національної ради України з питань телебачення та радіомовлення від 25.04.2024 р. №1337 науковому журналу «Техніка, енергетика, транспорт АПК» присвоєно ідентифікатор медіа R30-05173.

Журналу «Техніка, енергетика, транспорт АПК» присвоєно ідентифікатор цифрового об'єкта (Digital Object Identifier – DOI).

Журнал включений до міжнародних наукометричних баз і каталогів наукових праць:

- *Index Copernicus Value з 2018 року, сайт: <https://journals.indexcopernicus.com/search/details?id=47074>;*

- *Національної бібліотеки України ім. В.І. Вернадського, сайт: <http://www.irbis-nbuv.gov.ua>;*

- *Google Академія, сайт: <https://scholar.google.com.ua/citations?user=A5layLAAAAAJ&hl=uk>;*

- *CrossRef, сайт: <https://www.crossref.org>.*

Головний редактор

Олексій ТОКАРЧУК – к.т.н., доцент,
Вінницький національний аграрний університет

Заступник головного редактора

Віталій ЯРОПУД – к.т.н., доцент,
Вінницький національний аграрний університет

Відповідальний секретар

Юрій ПОЛЄВОДА – к.т.н., доцент,
Вінницький національний аграрний університет

Члени редакційної колегії

Олег ЦУРКАН – д.т.н., професор,
Вінницький національний аграрний університет

Сергій ШАРГОРОДСЬКИЙ – к.т.н., доцент,
Вінницький національний аграрний університет

Володимир БУЛГАКОВ – д.т.н., професор,
академік НААН України, Національний університет
біоресурсів і природокористування України

Валерій ГРАНЯК – к.т.н., доцент,
Вінницький національний аграрний університет

Ростислав ІСКОВИЧ-ЛОТОЦЬКИЙ – д.т.н.,
професор, Вінницький національний технічний
університет

Анатолій СПІРИН – к.т.н., доцент,
Вінницький національний аграрний університет

Юлія САЛЕНКО – д.т.н., професор, Кременчуцький
національний університет імені Михайла
Остроградського

Олена СОЛОНА – к.т.н., доцент,
Вінницький національний аграрний університет

Ігор КУПЧУК – к.т.н., доцент,
Вінницький національний аграрний університет

Ігор ТВЕРДОХЛІБ – к.т.н., доцент,
Вінницький національний аграрний університет

Ярослав ІВАНЧУК – д.т.н., професор,
Вінницький національний технічний університет

Зарубіжні члени редакційної колегії

Йордан МАКСИМОВ – д.т.н., професор,
Технічний університет Габрово (Болгарія)

Аудріус ЖУНДА – к.т.н., доцент,
Університет Вітовта Великого (Литва)

відповідальний секретар редакції – **Полєвода Ю.А.** к.т.н., доцент,

літературний редактор української та іноземних мов – **Погранична Н.М.**,

Адреса редакції: 21008, Вінниця, вул. Сонячна 3, Вінницький національний аграрний університет, тел. (0432) 46–00–03

Сайт журналу: <http://tetapk.vsau.org/>

Електронна адреса: pophv@ukr.net

**ENGINEERING,
ENERGY,
TRANSPORT AIC**

Journal of scientific, industrial and educational direction
Publisher: Vinnytsia National Agrarian University

It was founded in 1997 under the name "Bulletin of the Vinnytsia State Agricultural Institute".
Successor publication: Collection of Scientific Works of the Vinnytsia National Agrarian University. Series: Technical sciences.
Certificate of state registration of mass media
KV No. 16644–5116 PR dated 04/30/2010

Scientific journal "Technology, Energy, Transport AIC" / Editorial board: Tokarchuk O.A. (chief editor) and others. Vinnytsia, 2024. Vol. 126, № 3, P. 1-92.

Printed by decision of the Academic Council of the Vinnytsia National Agrarian University (protocol №. 6 dated December 24, 2024)

Certificate of state registration of mass media No. 21906-11806 R dated March 12, 2016.

The journal "Technology, Energy, Transport AIC" is included in the list of technical scientific publications of Ukraine (Category "B", Order of the Ministry of Education and Science of Ukraine dated 07.02.2020 No. 886).

According to the decision of the National Council of Ukraine on Television and Radio Broadcasting dated 04/25/2024 No. 1337, the scientific journal " Technology, Energy, Transport AIC " was assigned the media identifier R30-05173.

The journal " Technology, Energy, Transport AIC " has been assigned a digital object identifier (DOI).

The journal is included in the international scientometric bases and catalogs of scientific works:

- Index Copernicus Value since 2018, website: <https://journals.indexcopernicus.com/search/details?id=47074>;
- National Library of Ukraine named after V.I. Vernadskyi, website: <http://www.irbis-nbuv.gov.ua>;
- Google Academy, website: <https://scholar.google.com.ua/citations?user=A5layLAAAAAJ&hl=uk>;
- CrossRef, website: <https://www.crossref.org>.

Chief editor

Olexii TOKARCHUK – Candidate of Technical Sciences, Associate Professor, Vinnytsia National Agrarian University (Ukraine)

Deputy editor-in-chief

Vitalii YAROPUD – Candidate of Technical Sciences, Associate Professor, Vinnytsia National Agrarian University (Ukraine)

Responsible secretary

Yuriy POLIEVODA – Candidate of Technical Sciences, Associate Professor, Vinnytsia National Agrarian University (Ukraine)

Members of the editorial board

Oleg TSURKAN – Doctor of Technical Sciences, Full Professor, Vinnytsia National Agrarian University (Ukraine)

Volodymyr BULGAKOV – Doctor of Technical Sciences, Full Professor, Acad. NAAS, National University of Life and Environmental Sciences of Ukraine (Ukraine)

Rostislav ISKOVICH-LOTOTSKY – Doctor of Technical Sciences, Full Professor, Vinnytsia National Technical University (Ukraine)

Yuliia SALENKO – Doctor of Technical Sciences, Full Professor, Kremenchuk Mykhailo Ostrohradskyi National University (Ukraine)

Igor KUPCHUK – Candidate of Technical Sciences, Associate Professor, Vinnytsia National Agrarian University (Ukraine)

Serhii SHARHORODSKYI – Candidate of Technical Sciences, Associate Professor, Vinnytsia National Agrarian University (Ukraine)

Valerii HRANIAK – Candidate of Technical Sciences, Associate Professor, Vinnytsia National Agrarian University (Ukraine)

Anatoly SPIRIN – Candidate of Technical Sciences, Associate Professor, Vinnytsia National Agrarian University (Ukraine)

Olena SOLONA – Candidate of Technical Sciences, Associate Professor, Vinnytsia National Agrarian University (Ukraine)

Igor TVERDOKHLIB – Candidate of Technical Sciences, Associate Professor, Vinnytsia National Agrarian University (Ukraine)

Yaroslav IVANCHUK – Doctor of Technical Sciences, Full Professor, Vinnytsia National Technical University (Ukraine)

Foreign members of the editorial board

Jordan Todorov MAXIMOV – Doctor of Technical Sciences, Full Professor, Technical University of Gabrovo (Bulgaria)

Audrius ŽUNDA – Ph.D., Associate Professor, Vytautas Magnus University (Kaunas, Lithuania)

editor-in-chief – **Yurii POLIEVODA**, Candidate of Technical Sciences, Associate Professor,
literary editor of Ukrainian and foreign languages – **Natalia POGRANICHNA**

Address of the editorial office: 21008, Vinnytsia, str. Sonyakna 3, Vinnytsia National Agrarian University, tel. (0432)46-00-03

The magazine's website: <http://tetapk.vsau.org/>

E-mail address: pophv@ukr.net



ЗМІСТ

I. ПРИКЛАДНА МЕХАНІКА. МАТЕРІАЛОЗНАВСТВО. ГАЛУЗЕВЕ МАШИНОБУДУВАННЯ

<i>ГОРБЕНКО Олександр Вікторович, ПАДАЛКА Вячеслав Вікторович, ХАРАК Руслан Миколайович</i> ОБҐРУНТУВАННЯ ТЕХНОЛОГІЧНОГО ПРОЦЕСУ ВІДНОВЛЕННЯ РОБОЧИХ ПОВЕРХОНЬ З'ЄДНАНЬ ВАЛЬНИЦЬ КОЧЕННЯ.....	7
<i>КУПЧУК Ігор Миколайович</i> СТРУКТУРНО-ФУНКЦІОНАЛЬНЕ ПРОТОТИПУВАННЯ ВИКОНАВЧОЇ ЧАСТИНИ АНГУЛЯРНОГО РОБОТА-МАНІПУЛЯТОРА.....	12
<i>ШВЕЦЬ Людмила Василівна, ЧМИХ Катерина В'ячеславівна</i> ДОСЛІДЖЕННЯ ТЕЧІЇ МЕТАЛУ ІЗ АЛЮМІНІЄВОГО СПЛАВУ АК6 НА МОДЕРНІЗОВАНІЙ УСТАНОВЦІ ДЛЯ ГАРЯЧОГО ПРОКАТУВАННЯ.....	23
<i>ЯРОПУД Віталій Миколайович</i> АЛГОРИТМ РОБОТИ МЕХАТРОННОЇ СИСТЕМИ ЗАБЕЗПЕЧЕННЯ МІКРОКЛІМАТУ СВИНАРСЬКИХ ПРИМІЩЕНЬ.....	36
<i>ЯРОПУД Віталій Миколайович, ДАЦЮК Дмитро Анатолійович</i> ІННОВАЦІЙНІ МЕТОДИ ПІДВИЩЕННЯ ЕФЕКТИВНОСТІ РОБОТИ СЕЛЕКЦІЙНИХ СІВАЛОК.....	48

II. АГРОІНЖЕНЕРІЯ

<i>КОВАЛЬЧУК Юрій Олексійович, ВОЙТІК Андрій Володимирович, КОВАЛЬЧУК Андрій Олексійович</i> ДОСЛІДЖЕННЯ ЛАЗЕРНОГО ЗМІЦНЕННЯ ДЕТАЛЕЙ АВТОМОБІЛЬНОГО ТРАНСПОРТУ В АПК.....	58
<i>КОЛЄСНИК Іван Васильович, КАЛІНІН Євген Іванович, КОЛЄСНИК Юліана Ігорівна</i> ВПЛИВ ТИПУ ТЯГОВО-ЗЧІПНОГО ПРИСТРОЮ НА ПЕРЕРОЗПОДІЛ ГАЛЬМІВНИХ МОМЕНТІВ ПРИ ЗМІНІ ЕКСПЛУАТАЦІЙНИХ ТА КОНСТРУКТИВНИХ ФАКТОРІВ ПРИЧЕПА.....	65

III. ЕЛЕКТРОЕНЕРГЕТИКА, ЕЛЕКТРОТЕХНІКА ТА ЕЛЕКТРОМЕХАНІКА

<i>ГРАНЯК Валерій Федорович, САФТЮК Ярослав Владиславович</i> ОСОБЛИВОСТІ ВПЛИВУ КОРОТКОГО ЗАМИКАННЯ СТАТОРНОЇ ОБМОТКИ АСИНХРОННОГО ДВИГУНА НА СПЕКТРАЛЬНИЙ СКЛАД ЙОГО СТАТОРНОГО СТРУМУ.....	75
<i>ПОКРОВСЬКИЙ Костянтин Борисович</i> ОЦІНКА ЕФЕКТИВНОСТІ ВІТРОГЕНЕРАТОРІВ В УМОВАХ УЧАСТІ У ДОБОВОМУ РИНКУ ЕЛЕКТРОЕНЕРГІЇ.....	80
<i>ВОЗНЯК Олександр Миколайович, ТИХОНЕНКО Сергій Володимирович, ТИХОНОВ Володимир Костянтинівич, КОСАКОВСЬКИЙ Артем Юрійович</i> ОПТИМІЗАЦІЯ ЦИФРОВОЇ СИСТЕМИ КЕРУВАННЯ СТРУМОМ ЕЛЕКТРОПРИВОДА З ТИРИСТОРНИМ ПЕРЕТВОРЮВАЧЕМ.....	86

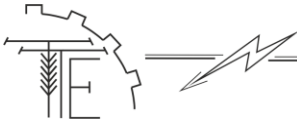

CONTENTS

I. APPLIED MECHANICS. MATERIALS SCIENCE. INDUSTRY MACHINERY BUILDING

<i>Oleksandr HORBENKO, Viacheslav PADALKA, Ruslan KHARAK</i> RATIONALE FOR THE TECHNOLOGICAL PROCESS OF RESTORATION OF WORKING SURFACES OF JOININGS OF ROLLING BEARINGS.....	7
<i>Ihor KUPCHUK</i> STRUCTURAL AND FUNCTIONAL PROTOTYPING OF THE EXECUTIVE PART OF THE ANGULAR MANIPULATOR ROBOT.....	12
<i>Lyudmila SHVETS, Kateryna CHMYKH</i> INVESTIGATION OF METAL FLOW FROM AK6 ALUMINUM ALLOY ON A MODERNIZED HOT ROLLING INSTALLATION.....	23
<i>Vitaliy YAROPUD</i> ALGORITHM OF OPERATION OF THE MECHATRONIC SYSTEM FOR PROVIDING MICROCLIMATE OF PIGSTIES.....	36
<i>Vitaliy YAROPUD, Dmytro DATSIUK</i> INNOVATIVE METHODS OF INCREASING THE EFFICIENCY OF SELECTING PLANTS.	48

II. AGROENGINEERING

<i>Yuriy KOVALCHUK, Andriy VOITIK, Andriy KOVALCHUK</i> RESEARCH ON LASER HARDENING OF AUTOMOTIVE PARTS IN THE AGRICULTURAL INDUSTRY.....	58
<i>Ivan KOLESNIK, Yevhen KALININ, Yuliana KOLESNIK</i> THE INFLUENCE OF THE TYPE OF TRACTIONAL COUPLING DEVICE ON THE REDISTRIBUTION OF BRAKING TORQUES WHEN THE OPERATIONAL AND DESIGN FACTORS OF THE TRAILER CHANGE.....	65

III. ELECTRICAL ENERGY, ELECTRICAL ENGINEERING AND ELECTROMECHANICS

<i>Valerii HRANIAK, Yaroslav SAFTYUK</i> FEATURES OF THE INFLUENCE OF A SHORT CIRCUIT OF THE STATOR WINDING OF AN INDUCTION MOTOR ON THE SPECTRAL COMPOSITION OF ITS STATOR CURRENT.....	75
<i>Kostiantyn POKROVSKIY</i> EVALUATION OF THE EFFICIENCY OF WIND GENERATORS IN THE CONDITIONS OF PARTICIPATION IN THE DAILY ELECTRICITY MARKET.....	80
<i>Oleksandr VOZNIAK, Serhii TIKHONENKO, Artem KOSAKOVSKIY, Volodymyr TYKHONOV</i> OPTIMIZATION OF A DIGITAL CURRENT CONTROL SYSTEM FOR AN ELECTRIC DRIVE WITH A THYRISTOR CONVERTER.....	86

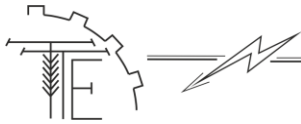

STRUCTURAL AND FUNCTIONAL PROTOTYPING OF THE EXECUTIVE PART OF THE ANGULAR MANIPULATOR ROBOT

Ihor KUPCHUK, Candidate of Technical Sciences, Associate Professor
Vinnitsia National Agrarian University

КУПЧУК Ігор Миколайович, к.т.н., доцент
Вінницький національний аграрний університет

In today's conditions of total digitization and informatization of all spheres of activity, more and more agro-industrial enterprises direct their resources to the development and implementation of modern technical and technological solutions, to modernize their own production capacities, with the prospect of ensuring competitiveness on domestic and foreign markets. In turn, such technological renewal of the agricultural sector of the economy is usually based on the use of high-tech systems of management, monitoring, control, management and automation of production processes, with the use of highly integrated SMART systems and the involvement of artificial intelligence technologies. Taking into account the significant volumes of cargo processing, agricultural enterprises, in particular in warehouses, a promising direction and reserve for ensuring high labor productivity is the use of robotic manipulators, and research is devoted to increasing their functionality and maneuverability, including through the use of intelligent control systems and optimization of the structure of executive mechanisms. relevant and will have practical value.

The article substantiates the conditions for ensuring functional and structural similarity and proposes criterion equations of similarity for a large-scale transition from a natural sample of an industrial manipulator to a physical model-prototype.

On the basis of the obtained criteria and using the scaling factors, the design parameters of the prototype were determined, a computer 3D model was developed, and based on the analysis of the trajectories, corrections were made to the linear dimensions of the manipulator and the ranges of angular movements of the links, as well as the compliance of the created prototype with the conditions of physical modeling was checked, according to the criteria of similarity.

Also, the article presents the process of manufacturing an angular manipulator by using additive technologies of layer-by-layer build-up of parts on a 3D printer.

Key words: trajectory, working area, similarity criterion, additive technologies, simulated computer model, 3D printing, computer model, maneuverability, degree of freedom.

Eq. 13. Fig. 10. Table. 1. Ref. 10.

1. Problem formulation

The need to increase the efficiency of the economic activity of agricultural enterprises leads to the introduction of modern technical and technological solutions, which are based on the use of high-tech systems of control, monitoring, management and automation of production processes [1]. The key component of this approach is the use of a wide range of technologies, such as global positioning systems (GPS, GLONASS), control systems, sensor control and monitoring systems, robotic systems, unmanned aerial vehicles, highly integrated smart systems, artificial intelligence systems [2, 3].

The economic activity of an agricultural enterprise is accompanied by the performance of a significant amount of work related to the loading, unloading and movement of various types of artificial cargo, which include rolls of hay, containers with fruits and vegetables, bags, packages, boxes, containers with liquid, large-sized parts and assemblies machines, etc. Work with artificial loads is meant not only directly during production processes, but also during auxiliary work (construction, repair, etc.). The variety of loading and unloading work determines the use of universal loaders and loading manipulators, but the





requirements to preserve the integrity of the cargo, impose a number of restrictions on the kinematic characteristics of the executive bodies and, as a result, reducing the productivity of cargo handling. Therefore, one of the promising ways to improve the efficiency of such works is to ensure labor productivity, which depends on the maneuverability of the machine and the qualifications of the operator. Therefore, research devoted to increasing the functional capabilities and maneuverability of manipulators, including through the use of intelligent control systems and optimization of the structure of executive mechanisms, are relevant.

2. Analysis of recent research and publications

In today's conditions, mechanical manipulators act as the main types of manipulation systems of industrial robots and are spatial mechanisms in the form of kinematic chains, which include links, kinematic pairs and drive systems, usually separate for each degree of freedom.

In general, the design of modern industrial robots provides for the use of a number of functionally similar structural elements (Fig. 1), which form two main subsystems of the robot: mechanical (manipulator) and control system [4, 5].

The manipulator, as a mechanical system, is a controlled multi-link spatial mechanism, the main components of which are the executive device that activates the working body in accordance with the given laws of motion, which ultimately allows the necessary technological operations to be performed.

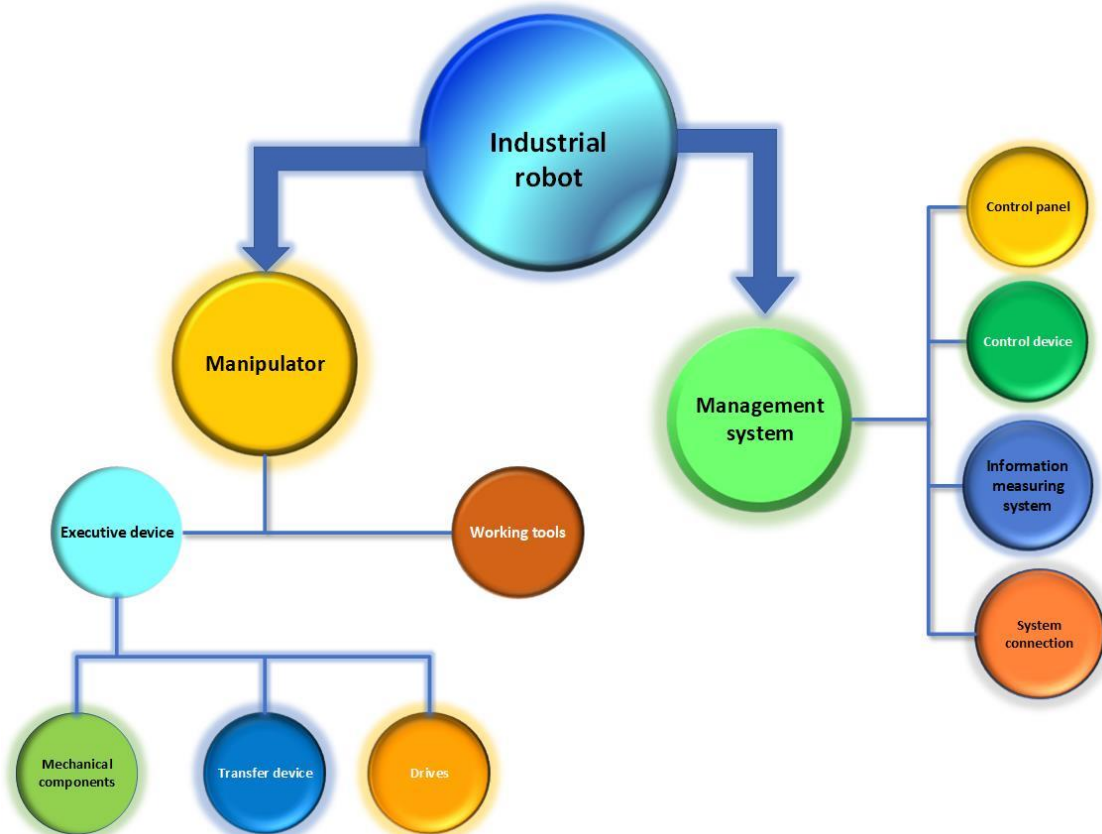
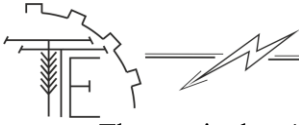

Fig. 1. Structural diagram of an industrial manipulator robot

The structure of the executive mechanism includes links interconnected by translational, rotational, cylindrical, spherical and other types of kinematic pairs, the combination of which allows to ensure the degree of freedom W necessary for the performance of the assigned tasks. The movement of the executive device is carried out using drives that connected with the help of mechanical components into a complete system and ensure the mobility of the mechatronic system as a whole.

Among the numerous technical characteristics of the manipulator (Fig. 2), on the basis of which the efficiency and suitability for the performance of tasks are evaluated, the degree of mobility, maneuverability, and the volume of the service area (the working area of the manipulator) are particularly important indicators that determine the functionality of the robot-manipulator) [6].



The manipulator's maneuverability is called its number of degrees of freedom with a stationary grip. The analysis of design features and maneuverability of various schemes of manipulators shows that maneuverability depends not only on the number of degrees of freedom of grip, but also on the location of kinematic pairs. Increasing the maneuverability of the manipulator allows you to perform movements of higher classes and increases the freedom of action of the operator when performing the necessary movements [6].

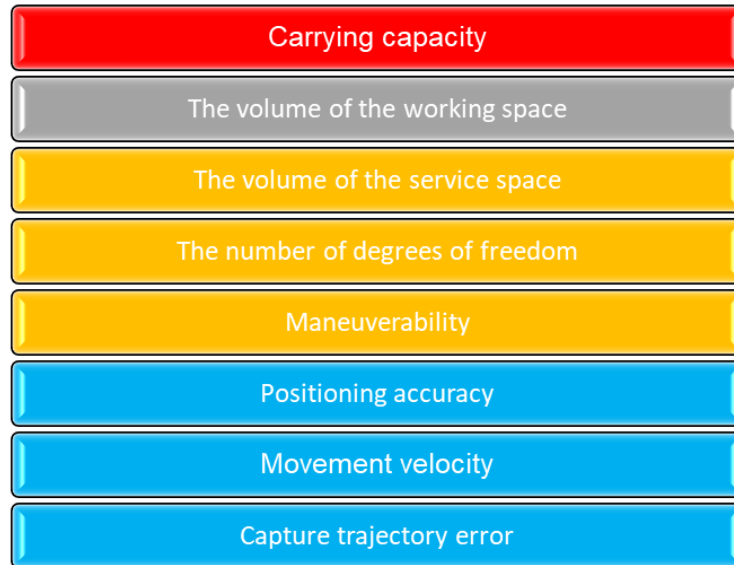

Fig. 2. Basic technical characteristics of the manipulator robot

For spatial mechanisms, the degree of mobility is determined by the Somov-Malyshev formula [6, 7]:

$$W = 6n - 5p_5 - 4p_4 - 3p_3 - 2p_2 - p_1, \quad (1)$$

where n – the number of moving links of the mechanism; p_i – the number of kinematic pairs of the corresponding class.

The type and parameters of the manipulator's working area determine the area of the surrounding space within which it can perform manipulations without moving, that is, with a stationary base.

The working area of the manipulator is the space in which its working body can be located in all possible positions of the manipulator links. The shape of the working zone is determined by the coordinate system in which the movement of the working body of the manipulator is carried out, and by the number of degrees of freedom of the manipulator [6]. To date, scientists have developed a number of constructive schemes of manipulators, but the basic and most common in the agro-industrial complex are four typical schemes presented in fig. 3 [2, 5].

Manipulators that work in a rectangular coordinate system (Fig. 3, a) have a working area in the shape of a parallelepiped. Here, all movements are only translational. Therefore, such a coordinate system is most convenient for rectilinear movements. In addition, it simplifies robot programming as much as possible, because it is usually performed in a rectangular coordinate system, and therefore, in this case, there is no need to transfer programs from one coordinate system to another [6].

In manipulators with a cylindrical coordinate system (Fig. 3, b), along with translational movements, angular movement (in a circle) is carried out. Accordingly, the working zone is limited by cylindrical surfaces [3, 6].

In the spherical coordinate system (Fig. 1, c), 2 angular movements are carried out and the working area is limited by spherical surfaces. Manipulators with such a coordinate system are, as a rule, more complex than with a cylindrical system, but more compact [5, 6].

An angular manipulator (Fig. 3, d) moves in an angular coordinate system and has only rotational kinematic pairs - hinges in its structure, which is why they are sometimes called hinged or anthropomorphic. A feature of this design is the possibility of folding the executive part, practically not exceeding the dimensions of the base, therefore, robots equipped with such manipulators have maximum compactness and maneuverability, as well as a much larger, compared to previously considered options, service area, but more difficult to control.

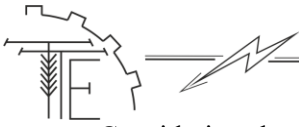

Considering the advantages of using manipulators that work in the angular coordinate system, it is possible to draw conclusions about the feasibility of developing and implementing this type of robots for maintenance of loading and unloading processes in agricultural production.

The main stages and stages that are foreseen in the design and manufacture of industrial manipulator robots are presented in fig. 4, from which it can be seen that the last stage, which precedes their implementation, is the conduct of tests for an already manufactured prototype, correction of working documentation and elimination of detected errors, performance failures and other deficiencies.

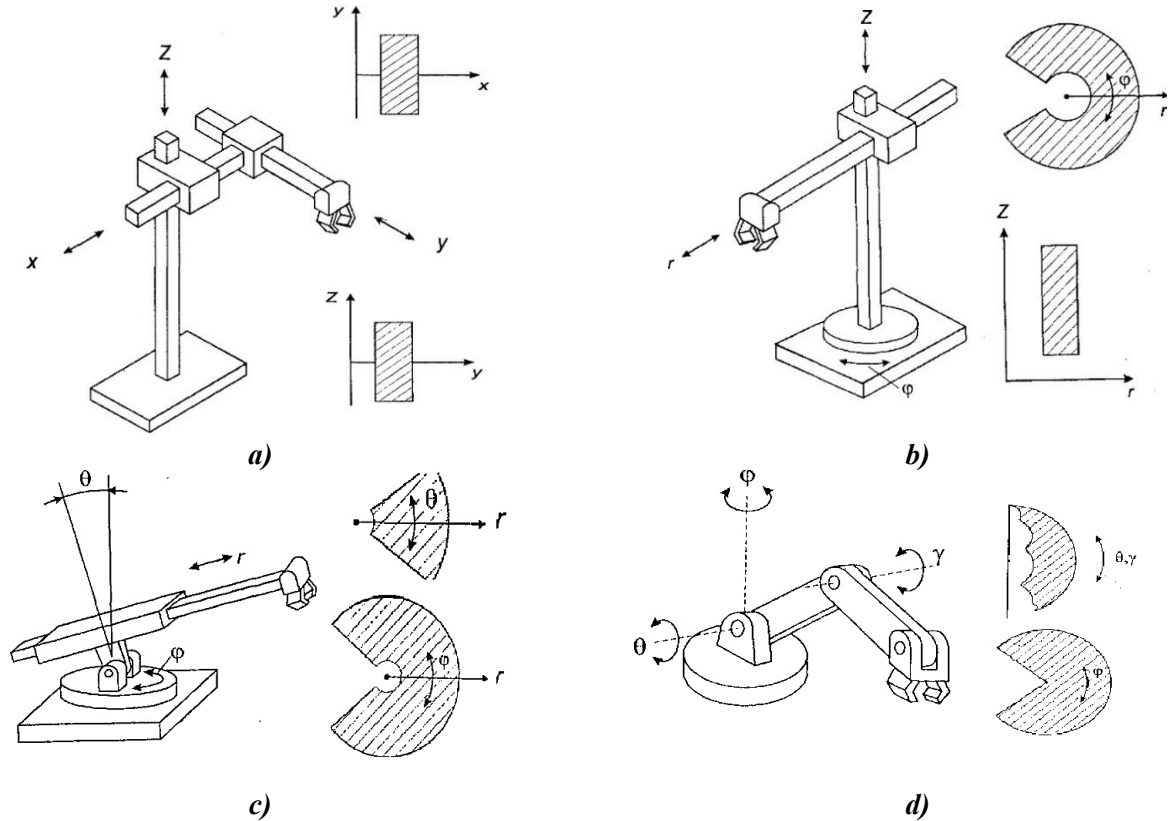

**Fig. 3. Classification of manipulators (by type of system of main coordinate movements):
a) rectangular; b) cylindrical; c) spherical; d) angular**

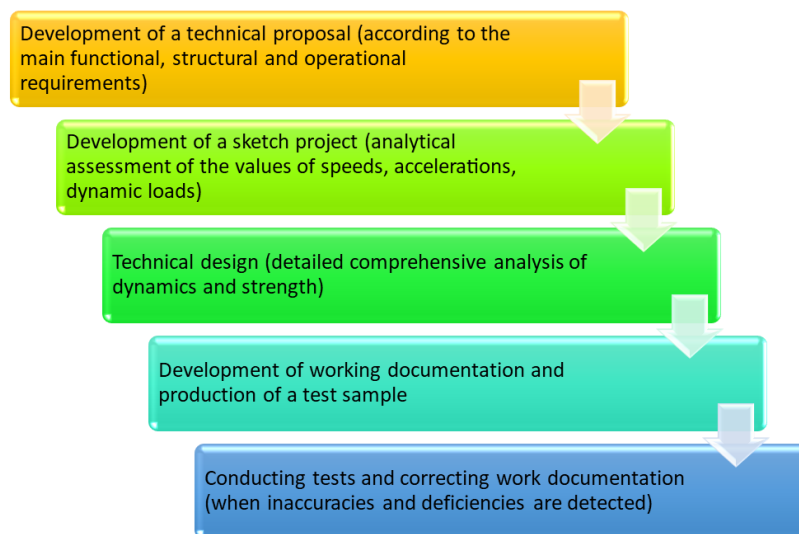
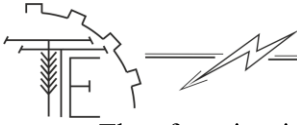

Fig. 4. The main stages of designing industrial manipulator robots

This type of production inspection at the final stages of design is characterized by unproductive consumption of material and labor resources, while the elimination of failures sometimes takes a lot of time.



Therefore, in view of the high cost of manufacturing an experimental prototype of a manipulator robot, as well as for the purpose of applying an alternative option for identifying and correcting possible structural flaws at the early stages of design, it would be a reasonable and justified step to create and work out errors on a physical model created using more cheap additive technologies.

3. The purpose of the article

The purpose of the research consists in forming the basis for the resource-saving creation of a highly maneuverable industrial manipulator robot by developing and substantiating the parameters of a physical model-prototype.

4. Results of the researches

The The industrial robot manipulator IRB 760-M07 (ABB Group, Switzerland), whose general appearance is presented in fig. 5, main operating characteristics – table 1 [8].

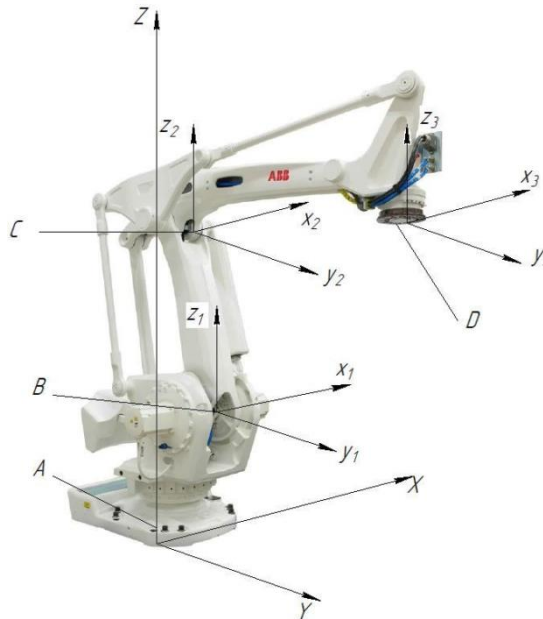

Fig. 5. Industrial manipulator robot IRB 760-M07 (ABB Group, Switzerland) [8]

The geometric characteristics of the volume of the working space and the service area were determined by processing the results of studies of possible movements and trajectories of the IRB 760-M07 robot links on a simulation computer model created in CAD SolidWorks Premium 2020 SP 1.0 [9]. The geometric parameters of the model details and the limits of movement along the axes were selected from the manufacturer's technical documentation [8].

Table 1

Ain operational characteristics of IRB 760-M07 [8]

	Indicator	Value
1	Maximum departure, mm	3180
2	Carrying capacity, kg	450
3	Number of axes	4
	Range of rotation, degrees:	
	A (XYZ), φ_0	+90...-90
	B (x1y1z1), φ_1	+85...-42
	C (x2y2z2), φ_2	+120...-20
	D (x3y3z3), φ_3	+300...-300
4	Supply voltage, V	200-600
5	Drive power consumption, kW	2,75
6	Base size, mm	1140x800
7	Weight, kg	2310

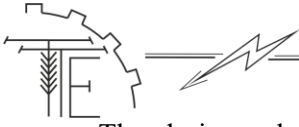

The design calculation of the parameters of the prototype was carried out using the concepts, theorems and axioms of the theory of similarity and physical modeling of technical systems, the development of the kinematic scheme - in accordance with the basic provisions of the theory of mechanisms and machines.

The parts were made by additively building up layers of a special polymer material based on digital model data on a KLEMA 180 3D printer (3D Device, Ukraine). Consumable material – plastic PET G 1.75 mm (Devil Design, Poland).

Digital model profiling software: CURA 15.04.6. The main parameters of the 3D printing process: the height of the application layer is 0.25 mm; the thickness of the outer wall is 1.2 mm; the thickness of the upper and lower layers is 0.2 mm; filling density - 100%; print speed – 30 mm/s; printing temperature – 210 °C; table temperature - 70 °C; fluidity of the material - 100%; the diameter of the extruder nozzle is 0.4 mm.

To achieve the goal, the task was set to design and develop a physical model-prototype of the executive part of the IRB 760 manipulator, subject to the structural and functional similarity of the model and the natural sample. That is, the structure of the prototype and the main parameters that characterize the functionality of the modeled version must be similar or proportional at the corresponding moment in time, at the same points in space as for the natural object.

In accordance with the formulated task, it was assumed that structural similarity can be achieved provided:

$$\begin{cases} W^N = W^M \\ M^N = M^M \\ N^N = N^M, \\ P_i^N = P_i^M \end{cases} \quad 2)$$

where W , m , n , p_i – respectively, the degree of mobility, maneuverability, the number of links, and the number of kinematic pairs of the i -th class; n is an index to indicate the parameters of a natural sample; m is an index to indicate the parameters of the physical model-prototype.

In addition, the number of possible local degrees of freedom for model and specimen links must also be the same.

Taking into account the initial conditions (2) and using the technical documentation of the industrial robot IRB 760-M07, a structural diagram (Fig. 6) was developed, on the basis of which it is planned to create a prototype. The executive mechanism (Fig. 6) has 4 rotating kinematic pairs of the 5th class (A, B, C, D), 4 moving links and a parallel mechanism for horizontal positioning of the gripping device (parallel to the XY plane).

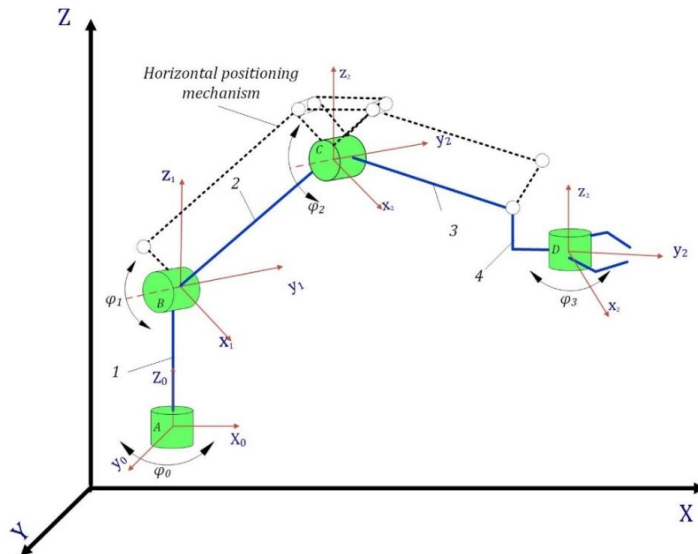
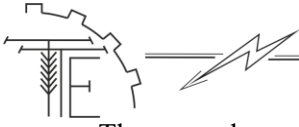

Fig. 6. Structural diagram of the IRB 760 industrial robot manipulator:

1 – base; 2 – shoulder; 3 – forearm; 4 – brush; XYZ – basic coordinate system; $x_i y_i z_i$ – local reference systems; φ_i – angular coordinate of the position of the i -th link in the system $x_i y_i z_i$ (rotation of the i -th link relative to $(i-1)$)



The general equation for finding the degree of mobility of such a spatial mechanism [7]:

$$W = \sum_{i=1}^5 (6 - i) \cdot p_i, \quad (3)$$

p_i – the number of kinematic pairs of the i -th class.

Since, for mechanisms that are made in the form of non-closed kinematic chains, expression (3) takes a simplified form [7]:

$$W = \sum_{i=1}^5 i \cdot p_i, \quad (4)$$

let's assume that the degree of mobility of the projected physical model and industrial sample IRB 760-M07 corresponds to the number of rotating kinematic pairs - $W=4$.

Thus, for a reliable mathematical description of the positions of the links of the executive mechanism of the designed prototype of an industrial robot, it is necessary to have values for four generalized coordinates.

According to the Somov-Malyshev formula (1) maneuverability:

$$m = 6 \cdot 3 - 5 \cdot 3 = 3,$$

which indicates the compliance of the scheme (Fig. 6) with the condition of functional ability ($m \geq 1$).

Thus, under the condition of accepting the gripping device as a material point (not taking into account its design features and inertial characteristics), for example point D, positioning in space can be described using three generalized coordinates.

The functionality of the physical model will be achieved in the case of ensuring the geometric similarity of the service area of the manipulation mechanism of the serial industrial robot and the model. In order to obtain information about the configuration of the service area, a 3D computer model created on a PC (Fig. 7) was studied, in which the shape, dimensions and ranges of angular movements of the links correspond to the actual values [9] of the IRB 760-M07 manipulator robot.

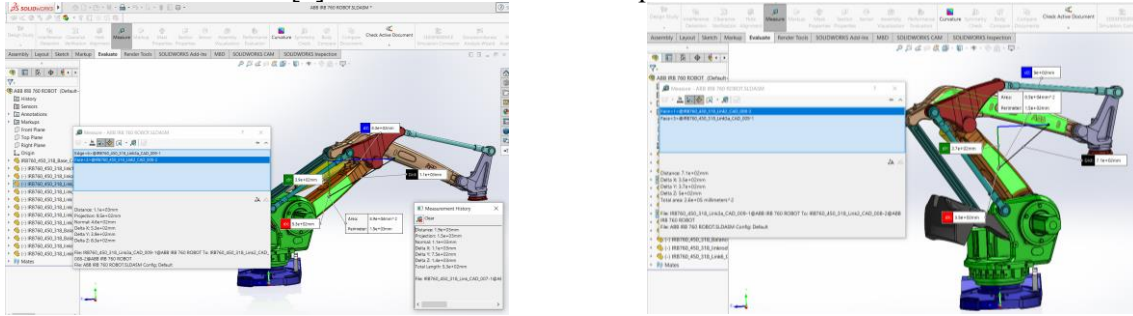

Fig 7. Simulation computer modeling of the movements of the links of the IRB 760-M07 manipulator robot in CAD SolidWorks Premium 2020 SP 1.0

As a result of the computer simulation of movements, we obtained the coordinates of point D when the gripper is located in the extreme positions, limited in accordance with the geometric dimensions of the links and working ranges of angular movements. Since the patterns of movement of point D parallel to XZ and YZ are identical, for further studies of kinematics and designing a physical model, it is sufficient to perform data analysis in only two orthogonal frames of reference - XOZ and XOY.

After placing D1...D6 on the scale and connecting them using a spline line, a trajectory curve was obtained for gripping the manipulator during parallel movement relative to XZ (Fig. 8, a) and XY (Fig. 8, b), which determine the boundaries service area IRB 760-M07.

Location in space of a kinematic pair D (sD) depends on the current position of links with constant linear dimensions $L_n = \text{const}$, which is given as a combination (C_φ) of angular coordinates $\varphi_0, \varphi_1, \varphi_2$:

$$C_\varphi = \begin{bmatrix} \Phi_0 \in [0, \pm 90^\circ] \\ \Phi_1 \in [+85^\circ, -42^\circ] \\ \Phi_2 \in [+120^\circ, -20^\circ] \end{bmatrix} \quad (5)$$

Taking (5) into account, the trajectory curve represents a functional dependence:

$$S_D = f(C_\varphi). \quad (6)$$

The location of the gripper in the service area can also be specified as a radius vector \vec{s}_D , with the beginning at point O of the base coordinate system XYZ and the end at point D. In this case, the trajectory will be the hodograph of the vector function:

$$s_D = \vec{s}_D(a, b \dots i), \quad (7)$$

where $a, b \dots i$ are the parameters of the vector function that determine the change in the radius vector \vec{s}_D .

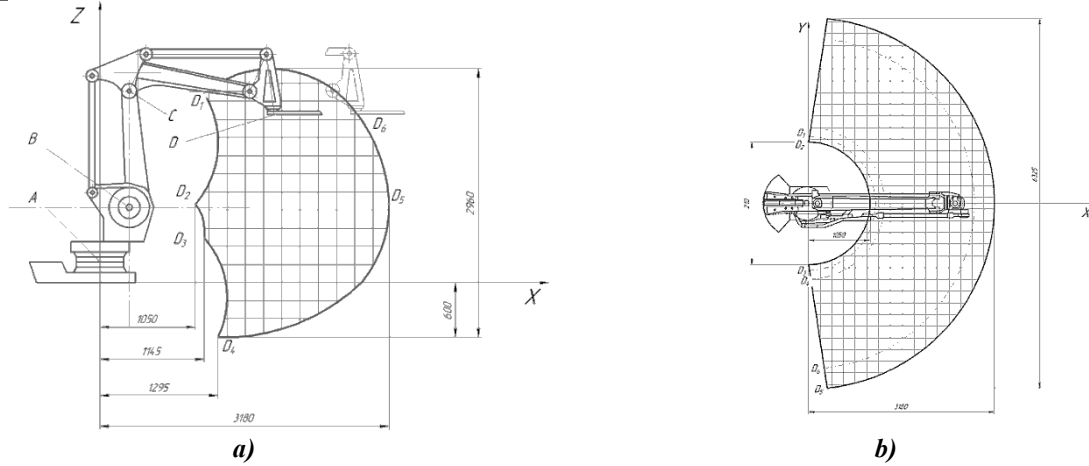
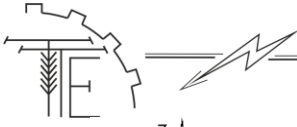

Fig. 8. Service area of the robot-manipulator IBR 720-M07: a) in the XZ plane; b) in the XY plane

The general equation for the analytical interpretation of the geometric similarity of the service area of the industrial model and the physical model:

$$\begin{cases} \sum_n \vec{s}_{D_n}^n(X, Y, Z) = \Pi_{\vec{s}(X, Y, Z)} \\ \sum_n \vec{s}_{D_n}^m(X, Y, Z) \times \vec{k}_{s(X, Y, Z)} = \Pi_{\vec{s}(X, Y, Z)} \end{cases}, \quad (8)$$

where $\Pi_{\vec{s}(X, Y, Z)}$ – the criterion of geometric similarity of the grip position of the manipulator in space.

$\vec{k}_{s(X, Y, Z)}$ – scale similarity coefficient.

Scaling conditions relative to three planes:

$$\begin{cases} \frac{\sum_n \vec{s}_{D_n}^n(X, Y)}{\sum_n \vec{s}_{D_n}^m(X, Y)} = \vec{k}_{s(X, Y)} \\ \frac{\sum_n \vec{s}_{D_n}^n(X, Z)}{\sum_n \vec{s}_{D_n}^m(X, Z)} = \vec{k}_{s(X, Z)}, \\ \frac{\sum_n \vec{s}_{D_n}^n(Y, Z)}{\sum_n \vec{s}_{D_n}^m(Y, Z)} = \vec{k}_{s(Y, Z)} \end{cases} \quad (9)$$

where $k_{s(X, Y)}$, $k_{s(X, Z)}$, $k_{s(Y, Z)}$ – similarity coefficients of the trajectories of the kinematic pair D in two-dimensional coordinate systems.

According to the 3rd theorem of M.V. Kirpichov, physical systems in which vector quantities are geometrically similar, and scalar quantities are proportional at the corresponding points in space and moment of time, can be considered similar [10]. Given that the possible variants of the trajectories in the XZ and YZ systems are identical:

$$k_{s(X, Z)} = k_{s(Y, Z)}; \quad (10)$$

$$k_{s(X, Y)} = k_{s(X, Z)} = k_{s(X, Y, Z)}, \quad (11)$$

then equation (9) will take the form:

$$\begin{cases} \frac{\sum_n \vec{s}_{D_n}^{nat}(X, Y)}{\sum_n \vec{s}_{D_n}^{mod}(X, Y)} = k_{s(X, Y, Z)} \\ \frac{\sum_n \vec{s}_{D_n}^{nat}(X, Z)}{\sum_n \vec{s}_{D_n}^{mod}(X, Z)} = k_{s(X, Y, Z)} \end{cases} \quad (12)$$

Taking into account the features of the structural scheme of the industrial manipulator (Fig. 6) and the configuration of the service area (Fig. 8) obtained by conducting a simulation computer experiment (Fig. 7), as well as equations (2), (8) and (12), a structural diagram (Fig. 9, a) and a 3D model (Fig. 9, b) of the manipulator, which will correspond to a natural sample of an industrial manipulator of the angular type (Fig. 5) in terms of structural and functional indicators, is designed in CAD.

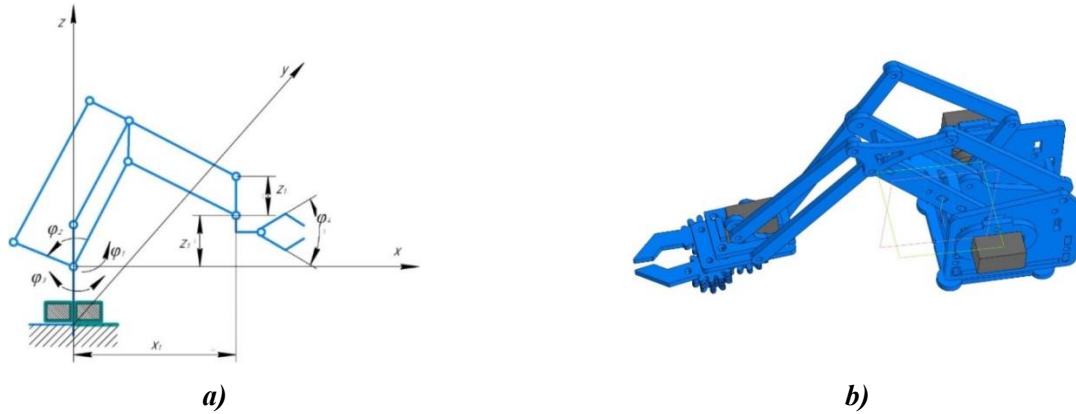

Fig. 9. Projected angular manipulator:
a) kinematic diagram, φ_1 – kut coordinate of shoulder position, φ_2 – angular coordinate of hand position, φ_3 – angular coordinate of rotation of the manipulator body, φ_4 – the angle of clamping the object by the gripping device; b) 3D model

The preparation of parts for printing was carried out in the CURA 15.04.6 software by forming profiles of digital models, the parts were made by additively building up layers of polymer material on a KLEMA 180 3D printer based on the Educational and Design Center for Agricultural Engineering of the Vinnitsia National Agrarian University (Fig. 10).

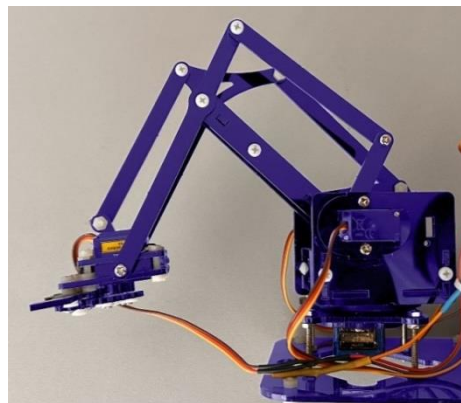

Fig. 10. The process of manufacturing parts of a physical model:
a) forming digital models for 3D printing; b) 3D printing of parts;
c) general view of a physical model

After 3D printing, characteristic stains on the parts were removed by mechanical cleaning, which is a necessary condition for their further use and assembly operations to create a physical model of the executive part of the industrial manipulator. Thus, the similarity conditions (2) are met in terms of mobility, maneuverability, number of links, and kinematic pairs of a certain class:



$$\begin{cases} W^N = W^M = 4 \\ M^N = M^M = 3 \\ N^N = N^M = 4 \\ P_i^N = P_i^M = 4 (V) \end{cases}, \quad (13)$$

indicates a similarity in the structure of the physical model and the natural sample, while the fulfillment of the condition of proportionality of link lengths and equality of ranges of rotation angles ensures geometric similarity of the service area, which determines the functional similarity of the compared objects.

5. Conclusions and prospects for further research

Thus, as a result of the conducted research, we built a 3D model of the manipulator, which allowed us to check the accuracy of the dimensions of the links and eliminate some shortcomings at an early stage of design, as well as, the analysis of the computer model and the study of the plan of the spatial mechanism allowed us to determine the design limitations, namely the angle ranges rotation of links and adjust geometric dimensions.

Using digital models of optimized dimensions, we printed a set of parts on a 3D printer and assembled a fully functional prototype - a physical model of an angular manipulator, which will be used in further research for practice and error elimination. In this way, the use of CAD and the use of additive prototyping technologies allows you to obtain information about the violation of the functionality of the robot and make corrections to the project at the initial stages, minimizing the unproductive consumption of resources.

By using the physical model, simulation studies can be conducted to determine the kinematic and dynamic parameters with sufficient accuracy for the design phase of a full-scale industrial manipulator.

References

1. Yaropud, V.M., Tverdokhlib, I.V., Spirin, A.V. (2020). *Mashyny ta obladnannia i yikh vykorystannia v roslynnytstvi [Machinery and equipment and their use in crop production]: tutorial*. Vinnytsia: VNAU. ISBN: 978-966-2007-67-1. [in Ukrainian].
2. Navulur, S., S.C.S. Sastry, A., N. Giri Prasad, M. (2017). Agricultural Management through Wireless Sensors and Internet of Things. *International Journal of Electrical and Computer Engineering (IJECE)*, 7(6), 3492. DOI: <https://doi.org/10.11591/ijece.v7i6.pp3492-3499>. [in English].
3. Khanna, D., Sharma, A. (2019). Internet of Things: Challenges, opportunities, and directions. *International Journal For Technological Research In Engineering*, 6(12), 6028–6030. [in English].
4. Loveikin, V.S., Romasevych, Yu.O., Chovniuk, Yu.V. (2012). *Mekhatronika [Mechatronics] : tutorial*. K. [in Ukrainian].
5. Solona, O.V. (2020). Zastosuvannia suchasnykh mekhatronnykh system ta robotyzovanykh kompleksiv u APK Ukrainy [Application of modern mechatronic systems and robotic complexes in the agricultural industry of Ukraine]. *Engineering, Energy, Transport AIC*, 3(110), 71–76. DOI: 10.37128/2520-6168-2020-3-7. [in Ukrainian].
6. Solona, O.V., Kupchuk, I.M. (2018). *Teoriia mekhanizmiv i mashyn. Kursove proektuvannia [Theory of mechanisms and machines. Course design]: tutorial. 2-he vyd., dopov. i pererob.* Vinnytsia: VNAU. [in Ukrainian].
7. Solona, O.V., Kupchuk, I.M. (2020). *Praktykum z teorii mekhanizmiv i mashyn [Workshop on the theory of mechanisms and machines]: tutorial*. Vinnytsia: TOV “Druk”. [in Ukrainian].
8. Robotics (2020). Product specification IRB 760. ABB. [in English].
9. Bolda, M., Pupăză, C. (2018). Dynamic simulation of industrial robots behaviour using integrated software procedures. *Proceedings in Manufacturing Systems*, 13 (1), 39–46. ISSN 2067-9238. [in English].
10. Yanovych, V.P., Kupchuk, I.M., Polevoda, Yu.A. (2014). Rozrobka metodyky masshtabnoho perekhodu “fizychna model – naturalnyi zrazok” pry proektuvanni vibrorotornoj drobarky spyrtovoi promyslovosti [Development of the methodology of the large-scale transition "physical model -



natural sample" in the design of the vibro-rotor crusher of the alcohol industry]. *Collection of scientific works of the Vinnytsia National Agrarian University. Series: Technical sciences, 1 (89), 164–167.* [in Ukrainian].

СТРУКТУРНО-ФУНКЦІОНАЛЬНЕ ПРОТОТИПУВАННЯ ВИКОНАВЧОЇ ЧАСТИНИ АНГУЛЯРНОГО РОБОТА-МАНІПУЛЯТОРА

У сучасних умовах тотальної цифровізації та інформатизації всіх сфер діяльності все більше агропромислових підприємств спрямовує свої ресурси на розробку та впровадження сучасних техніко-технологічних рішень, для модернізації власних виробничих потужностей, з перспективою забезпечення конкурентоспроможними на внутрішньому та зовнішніх ринках. В свою чергу, таке технологічне оновлення аграрного сектору економіки, зазвичай, базується на використанні високотехнологічних систем управління, моніторингу, контролю, управління та автоматизації виробничих процесів, із застосуванням високоінтегрованих SMART-систем та залученням технологій штучного інтелекту. Враховуючи значні обсяги вантажопереробки, сільськогосподарського підприємства, зокрема в складських приміщеннях, перспективним напрямком та резервом забезпечення високої продуктивності праці є використання роботизованих маніпуляторів, а дослідження присвячені підвищенню їх функціональності та маневреності, в тому числі за рахунок використання інтелектуальних систем управління та оптимізації структури виконавчих механізмів є актуальними та матимуть практичну цінність.

В статті обґрунтовано умови забезпечення функціональної та структурної подібності та запропоновані критеріальні рівняння подібності для масштабного переходу від натурального зразка промислового маніпулятора до фізичної моделі-прототипу.

На основі отриманих критеріїв та використавши коефіцієнти масштабування визначені конструктивні параметри прототипу, розроблено комп'ютерну 3D модель та на основі аналізу траєкторій внесені коректури лінійних розмірів маніпулятора та діапазонів кутових переміщень ланок, а також перевірено, за критеріями подібності, відповідність створюваного прототипу умовам фізичного моделювання.

Також, в статті представлено процес виготовлення ангулярного маніпулятора шляхом застосування адитивних технологій пошарового нарощення деталей на 3D-принтері.

Ключові слова: траєкторія, робоча зона, критерій подібності, адитивні технології, імітаційна комп'ютерна модель, 3D-друк, комп'ютерна модель, маневреність, ступінь вільності.

Ф. 13. Рис. 10. Табл. 1. Літ. 10.

INFORMATION ABOUT THE AUTHORS

Ihor KUPCHUK – Candidate of Technical Sciences, Associate professor Associate Professor of the Department of Engineering Mechanics and Technological Processes in the Agricultural Industry, Faculty of Engineering and Technology, Vinnytsia National Agrarian University (3, Sonychna St., Vinnytsia, 21008, Ukraine, e-mail: kupchuk.igor@i.ua, <http://orcid.org/0000-0002-2973-6914>).

КУПЧУК Ігор Миколайович – кандидат технічних наук, доцент кафедри інженерної механіки та технологічних процесів в АПК, інженерно-технологічний факультет, Вінницький національний аграрний університет (вул. Сонячна, 3, м. Вінниця, 21008, Україна, e-mail: kupchuk.igor@i.ua, <http://orcid.org/0000-0002-2973-6914>).