



Всеукраїнський науково-технічний журнал

All-Ukrainian Scientific & Technical Journal

ISSN 2520-6168 (Print)

DOI:10.37128/2520-6168-2024-4

Machinery
Energetics
Transport
of Agribusiness



ТЕХНІКА
ЕНЕРГЕТИКА
ТРАНСПОРТ АПК



Науковий журнал

**ТЕХНІКА,
ЕНЕРГЕТИКА,
ТРАНСПОРТ АПК**

№ 4 (127) / 2024

м. Вінниця – 2024

Scientific Journal

**Engineering,
Energy, Transport
AIC**

Vol 127, № 4 / 2024

Vinnytsia – 2024

**ТЕХНІКА,
ЕНЕРГЕТИКА,
ТРАНСПОРТ АПК**

Заснований у 1997 році під назвою «Вісник Вінницького державного сільськогосподарського інституту».
Правонаступник видання: Збірник наукових праць Вінницького національного аграрного університету. Серія: Технічні науки.
Свідоцтво про державну реєстрацію засобів масової інформації
КВ № 16644–5116 ПР від 30.04.2010 р.

Науковий журнал «Техніка, енергетика, транспорт АПК» / Редколегія: Токарчук О.А. (головний редактор) та інші. Вінниця, 2024. № 4 (127). С. 1-99.

Друкується за рішенням Вченої ради Вінницького національного аграрного університету (протокол № 6 від 24.12.2024 р.)

Свідоцтво про державну реєстрацію засобів масової інформації №21906-11806 Р від 12.03.2016р.

Журнал «Техніка, енергетика, транспорт АПК» включено до переліку наукових фахових видань України з технічних наук (Категорія «Б», Наказ Міністерства освіти і науки України від 02.07.2020 року №886).

Згідно рішення Національної ради України з питань телебачення та радіомовлення від 25.04.2024 р. №1337 науковому журналу «Техніка, енергетика, транспорт АПК» присвоєно ідентифікатор медіа R30-05173.

Журналу «Техніка, енергетика, транспорт АПК» присвоєно ідентифікатор цифрового об'єкта (Digital Object Identifier – DOI).

Журнал включений до міжнародних наукометричних баз і каталогів наукових праць:

- *Index Copernicus Value з 2018 року, сайт: <https://journals.indexcopernicus.com/search/details?id=47074>;*

- *Національної бібліотеки України ім. В.І. Вернадського, сайт: <http://www.irbis-nbuv.gov.ua>;*

- *Google Академія, сайт: <https://scholar.google.com.ua/citations?user=A5layLAAAAAJ&hl=uk>;*

- *CrossRef, сайт: <https://www.crossref.org>.*

Головний редактор

Олексій ТОКАРЧУК – к.т.н., доцент,
Вінницький національний аграрний університет

Заступник головного редактора

Віталій ЯРОПУД – к.т.н., доцент,
Вінницький національний аграрний університет

Відповідальний секретар

Юрій ПОЛЄВОДА – к.т.н., доцент,
Вінницький національний аграрний університет

Члени редакційної колегії

Олег ЦУРКАН – д.т.н., професор,
Вінницький національний аграрний університет

Сергій ШАРГОРОДСЬКИЙ – к.т.н., доцент,
Вінницький національний аграрний університет

Володимир БУЛГАКОВ – д.т.н., професор,
академік НААН України, Національний університет
біоресурсів і природокористування України

Валерій ГРАНЯК – к.т.н., доцент,
Вінницький національний аграрний університет

Ростислав ІСКОВИЧ-ЛОТОЦЬКИЙ – д.т.н.,
професор, Вінницький національний технічний
університет

Анатолій СПІРІН – к.т.н., доцент,
Вінницький національний аграрний університет

Юлія САЛЕНКО – д.т.н., професор, Кременчуцький
національний університет імені Михайла
Остроградського

Олена СОЛОНА – к.т.н., доцент,
Вінницький національний аграрний університет

Ігор КУПЧУК – к.т.н., доцент,
Вінницький національний аграрний університет

Ігор ТВЕРДОХЛІБ – к.т.н., доцент,
Вінницький національний аграрний університет

Ярослав ІВАНЧУК – д.т.н., професор,
Вінницький національний технічний університет

Зарубіжні члени редакційної колегії

Йордан МАКСИМОВ – д.т.н., професор,
Технічний університет Габрово (Болгарія)

Аудріус ЖУНДА – к.т.н., доцент,
Університет Вітовта Великого (Литва)

відповідальний секретар редакції – **Полєвода Ю.А.** к.т.н., доцент,

літературний редактор української та іноземних мов – **Погранична Н.М.**,

Адреса редакції: 21008, Вінниця, вул. Сонячна 3, Вінницький національний аграрний університет, тел. (0432) 46–00–03

Сайт журналу: <http://tetapk.vsau.org/>

Електронна адреса: pophv@ukr.net

**ENGINEERING,
ENERGY,
TRANSPORT AIC**

Journal of scientific, industrial and educational direction
Publisher: Vinnytsia National Agrarian University

It was founded in 1997 under the name "Bulletin of the Vinnytsia State Agricultural Institute".
Successor publication: Collection of Scientific Works of the Vinnytsia National Agrarian University. Series: Technical sciences.
Certificate of state registration of mass media
KV No. 16644–5116 PR dated 04/30/2010

Scientific journal "Technology, Energy, Transport AIC" / Editorial board: Tokarchuk O.A. (chief editor) and others. Vinnytsia, 2024. Vol. 127, № 4, P. 1-99.

Printed by decision of the Academic Council of the Vinnytsia National Agrarian University (protocol №. 6 dated December 24, 2024)

Certificate of state registration of mass media No. 21906-11806 R dated March 12, 2016.

The journal "Technology, Energy, Transport AIC" is included in the list of technical scientific publications of Ukraine (Category "B", Order of the Ministry of Education and Science of Ukraine dated 07.02.2020 No. 886).

According to the decision of the National Council of Ukraine on Television and Radio Broadcasting dated 04/25/2024 No. 1337, the scientific journal " Technology, Energy, Transport AIC " was assigned the media identifier R30-05173.

The journal " Technology, Energy, Transport AIC " has been assigned a digital object identifier (DOI).

The journal is included in the international scientometric bases and catalogs of scientific works:

- *Index Copernicus Value since 2018, website: <https://journals.indexcopernicus.com/search/details?id=47074>;*
- *National Library of Ukraine named after V.I. Vernadskyi, website: <http://www.irbis-nbuv.gov.ua>;*
- *Google Academy, website: <https://scholar.google.com.ua/citations?user=A5layLAAAAAJ&hl=uk>;*
- *CrossRef, website: <https://www.crossref.org>.*

Chief editor

Olexii TOKARCHUK – Candidate of Technical Sciences, Associate Professor, Vinnytsia National Agrarian University (Ukraine)

Deputy editor-in-chief

Vitalii YAROPUD – Candidate of Technical Sciences, Associate Professor, Vinnytsia National Agrarian University (Ukraine)

Responsible secretary

Yuriy POLIEVODA – Candidate of Technical Sciences, Associate Professor, Vinnytsia National Agrarian University (Ukraine)

Members of the editorial board

Oleg TSURKAN – Doctor of Technical Sciences, Full Professor, Vinnytsia National Agrarian University (Ukraine)

Volodymyr BULGAKOV – Doctor of Technical Sciences, Full Professor, Acad. NAAS, National University of Life and Environmental Sciences of Ukraine (Ukraine)

Rostislav ISKOVICH-LOTOTSKY – Doctor of Technical Sciences, Full Professor, Vinnytsia National Technical University (Ukraine)

Yuliia SALENKO – Doctor of Technical Sciences, Full Professor, Kremenchuk Mykhailo Ostrohradskyi National University (Ukraine)

Igor KUPCHUK – Candidate of Technical Sciences, Associate Professor, Vinnytsia National Agrarian University (Ukraine)

Serhii SHARHORODSKYI – Candidate of Technical Sciences, Associate Professor, Vinnytsia National Agrarian University (Ukraine)

Valerii HRANIAK – Candidate of Technical Sciences, Associate Professor, Vinnytsia National Agrarian University (Ukraine)

Anatoly SPIRIN – Candidate of Technical Sciences, Associate Professor, Vinnytsia National Agrarian University (Ukraine)

Olena SOLONA – Candidate of Technical Sciences, Associate Professor, Vinnytsia National Agrarian University (Ukraine)

Igor TVERDOKHLIB – Candidate of Technical Sciences, Associate Professor, Vinnytsia National Agrarian University (Ukraine)

Yaroslav IVANCHUK – Doctor of Technical Sciences, Full Professor, Vinnytsia National Technical University (Ukraine)

Foreign members of the editorial board

Jordan Todorov MAXIMOV – Doctor of Technical Sciences, Full Professor, Technical University of Gabrovo (Bulgaria)

Audrius ŽUNDA – Ph.D., Associate Professor, Vytautas Magnus University (Kaunas, Lithuania)

editor-in-chief – **Yurii POLIEVODA**, Candidate of Technical Sciences, Associate Professor,
literary editor of Ukrainian and foreign languages – **Natalia POGRANICHNA**

Address of the editorial office: 21008, Vinnytsia, str. Sonyakna 3, Vinnytsia National Agrarian University, tel. (0432)46-00-03

The magazine's website: <http://tetapk.vsau.org/>

E-mail address: pophv@ukr.net



ЗМІСТ

I. ПРИКЛАДНА МЕХАНІКА. МАТЕРІАЛОЗНАВСТВО. ГАЛУЗЕВЕ МАШИНОБУДУВАННЯ

<i>ПАЛАДІЙЧУК Юрій Богданович, ТЕЛЯТНИК Інна Анатоліївна, КУБАЙ Марина Григорівна</i> МЕТАЛОГРАФІЧНЕ ДОСЛІДЖЕННЯ ЗМІНИ СТРУКТУРИ ДЕФОРМОВАНОГО ШАРУ МЕТАЛУ ПРИ ГІДРОІМПУЛЬСНОМУ ВИГЛАЖУВАННІ.....	7
<i>ПАНАСЕНКО Володимир Володимирович, ДЕЙНЕКА Дмитро Миколайович</i> ОСОБЛИВОСТІ ПРОЦЕСУ ДИСТИЛЯЦІЇ ДІЕТІЛАМІНУ З ВОДНОГО РОЗЧИНУ ХЛОРИДУ КАЛЬЦІЯ.....	23
<i>ТРУХАНСЬКА Олена Олександрівна, ГАДАЙЧУК Максим Юрійович</i> АНАЛІЗ КОНСТРУКТИВНО-ТЕХНОЛОГІЧНИХ АСПЕКТІВ ФУНКЦІОНУВАННЯ КОПАЧІВ КОРЕНЕПЛОДІВ ЦИКОРІЮ.....	30
<i>ШТУЦЬ Андрій Анатолійович, БАБИН Ігор Анатолійович, ЛУЦ Павло Михайлович</i> ДОСЛІДЖЕННЯ ПРОЦЕСІВ ШТАМПУВАННЯ ОБКОЧУВАННЯМ ПРИ ФОРМУВАННІ ФЛАНЦІВ ТРУБОПРОВІДІВ.....	38

II. АГРОІНЖЕНЕРІЯ

<i>КРАВЕЦЬ Світлана Миколаївна</i> ПЕРСПЕКТИВИ РОЗВИТКУ ВОДНЕВОЇ ЕНЕРГЕТИКИ: ІННОВАЦІЙНІ ТЕХНОЛОГІЇ ЯК КЛЮЧ ДО ЗДЕШЕВЛЕННЯ «ЗЕЛЕНОГО» ВОДНЮ.....	46
<i>РЯБОШАПКА Вадим Борисович</i> КОМПЛЕКСНЕ ДОСЛІДЖЕННЯ КРИТЕРІЇВ ДОЦІЛЬНОСТІ ВИРОБНИЦТВА БІОДИЗЕЛЬНОГО ПАЛИВА НА БАЗІ ФЕРМЕРСЬКИХ ГОСПОДАРСТВ.....	57
<i>ТРУХАНСЬКА Олена Олександрівна, ПЕРХАЙЛО Богдан Павлович</i> ТЕНДЕНЦІЇ ЗАСТОСУВАННЯ НОВИХ ТЕХНОЛОГІЙ І МАШИН ДЛЯ ЗБИРАННЯ БІОНЕРГЕТИЧНИХ КУЛЬТУР.....	70
<i>ШВЕЦЬ Людмила Василівна, ПАВЛЮК Дарина Олександрівна</i> ДОСЛІДЖЕННЯ ТА РОЗРОБКА АГРЕГАТУ ДЛЯ ЗРІЗАННЯ ГІЛОК ІЗ ПОДРІБНЕННЯМ І ЗМІШУВАННЯМ ЇХ ІЗ ҐРУНТОМ.....	76
<i>ШВЕЦЬ Людмила Василівна, ШВЕЦЬ Олександр Ігорович</i> РОЗРОБКА ТА ЕФЕКТИВНІСТЬ ВИКОРИСТАННЯ ГІДРАВЛІЧНОГО ПОДРІБНЮВАЧА ДЕРЕВИНИ ЯК ІНСТРУМЕНТУ ДЛЯ ПІДГОТОВКИ АЛЬТЕРНАТИВНОГО ПАЛИВА.....	84

III. ЕЛЕКТРОЕНЕРГЕТИКА, ЕЛЕКТРОТЕХНІКА ТА ЕЛЕКТРОМЕХАНІКА

<i>ГРАНЯК Валерій Федорович, ТОКАРЧУК Олексій Анатолійович</i> РОЗРОБКА КОНЦЕПЦІЇ РЕАЛІЗАЦІЇ МІКРОПРОЦЕСОРНОЇ СИСТЕМИ ВИМІРЮВАЛЬНОГО КОНТРОЮ ТЕМПЕРАТУРИ ТЕПЛИЧНИХ КОМПЛЕКСІВ.....	91
--	-----------

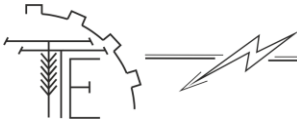

CONTENTS

I. APPLIED MECHANICS. MATERIALS SCIENCE. INDUSTRY MACHINERY BUILDING

*Yurii PALADIICHUK, Inna TELIATNYK, Maryna KUBAI***METALLOGRAPHIC STUDY OF CHANGES IN THE STRUCTURE OF A DEFORMED METAL LAYER DURING WATER-PULSE SMOOTHING..... 7***Volodymyr PANASENKO, Dmytro DEINEKA***PECULIARITIES OF DIETHYLAMINE DISTILLATION PROCESS FROM CALCIUM CHLORIDE AQUEOUS SOLUTION..... 23***Olena TRUKHANSKA, Maksym HADAICHUK***ANALYSIS OF DESIGN AND TECHNOLOGICAL ASPECTS OF FUNCTIONING OF CHICORY ROOT DIGGERS..... 30***Andrii SHTUTS, Ihor BABYN, Pavlo LUTS***STUDY OF STAMPING AND ROLLING PROCESSES IN THE FORMATION OF PIPELINE FLANGES..... 38**

II. AGROENGINEERING

*Svetlana KRAVETS***PROSPECTS FOR THE DEVELOPMENT OF HYDROGEN ENERGY: INNOVATIVE TECHNOLOGIES AS THE KEY TO REDUCING THE PRICE OF “GREEN” HYDROGEN... 46***Vadym RYABOSHAPKA***COMPREHENSIVE STUDY OF THE FEASIBILITY CRITERIA FOR BIODIESEL PRODUCTION BASED ON FARMING ENTERPRISES..... 57***Olena TRUKHANSKA, Bohdan PERKHAILO***TRENDS IN THE APPLICATION OF NEW TECHNOLOGIES AND MACHINES FOR HARVESTING BIOENERGY CROPS..... 70***Lyudmila SHVETS, Daryna PAVLYUK***RESEARCH AND DEVELOPMENT OF UNIT FOR CUTTING BRANCHES WITH CROPPING AND MIXING THEM WITH SOIL..... 76***Lyudmila SHVETS, Oleksandr SHVETS***DEVELOPMENT AND EFFICIENCY OF USING A HYDRAULIC WOOD CHIPPER AS A TOOL FOR THE PREPARATION OF ALTERNATIVE FUEL..... 84**

III. ELECTRICAL ENERGY, ELECTRICAL ENGINEERING AND ELECTROMECHANICS

*Valerii HRANIAK, Oleksii TOKARCHUK***DEVELOPMENT OF A CONCEPT FOR THE IMPLEMENTATION OF A MICROPROCESSOR SYSTEM FOR MEASURING THE TEMPERATURE OF GREENHOUSE COMPLEXES..... 91**

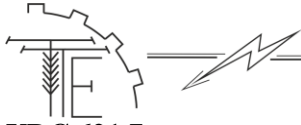

DEVELOPMENT AND EFFICIENCY OF USING A HYDRAULIC WOOD CHIPPER AS A TOOL FOR THE PREPARATION OF ALTERNATIVE FUEL

Lyudmila SHVETS, Candidate of Technical Sciences, Associate Professor
Oleksandr SHVETS, Recipient of the Second Educational and Qualification Level
Vinnytsia National Agrarian University

ШВЕЦЬ Людмила Василівна, к.т.н., доцент
ШВЕЦЬ Олександр Ігорович, здобувач другого освітньо-кваліфікаційного рівня
Вінницький національний аграрний університет

The main question that a person asks himself when he needs to provide heat to his home. In the current, military time in Ukraine: how to do it more profitably, with the current level of comfort? Everyone chooses for himself, manufacturers of energy production equipment (gas, liquid or solid fuel boilers, electric heating devices, solar installations, heat pumps) conduct an active advertising campaign, trying to prove that their equipment is the most profitable and the best. The average consumer, not having relevant experience, usually makes a spontaneous decision, basing his choice on advertising or the seller's beliefs. For the use of alternative fuel resources, namely wood, we offer to consider the development of a hydraulic wood chipper, which makes human labor much easier.

The cheapest way to heat a country house is a boiler running on solid fuel (firewood, anthracite). But it should be understood that together with the relative cheapness of heat with this heating method, a number of problems arise related to fuel storage and the need for constant maintenance of the boiler: its loading, ignition and cleaning. Should you save money and equip your house with a solid fuel boiler, or should you choose a gas boiler (or a liquid fuel one that runs on fuel oil), during which the entire production process is fully automatic? The choice is yours. But in any case, as you can see, stopping your choice on electric heating, solar equipment or a heat pump for no particular reason is probably not worth it yet: these technologies are still too expensive for widespread use today.

At present, firewood was and is the most ecological and economical type of fuel. Therefore, the owners wonder how to make it easier to collect firewood in order to preserve their health.

A log shredder with a hydraulic system is the best assistant for the owner to prepare an alternative source of energy for the heating season. It is easy to operate - you only need to install a deck, press a button or a lever. The log is divided smoothly and without contact with the person, which is over security. The force of the hydraulic system is enormous, reaching 4-6 tons, the shredder can work with different types of wood and at high speed.

Key words: log, hydraulic chipper, wood chipper, solid fuel boiler, alternative fuel.

Eq. 1. Fig. 5. Ref. 11.

1. Problem formulation

During the heating season, there is a problem of fuel resources and cost savings for their purchase, with the increase in energy carriers (gas, fuel oil, coal) there is a way out in the use of alternative types of fuel. As an energy resource, biomass is widely used in the agriculture of Poland, Hungary, the Czech Republic and other European countries. By-products of agro-industrial production are used for heating - straw of grain crops, stalks of corn and sunflower, firewood from trees. These energy resources can be effectively disposed of if they are located at short distances from the heating object and their quantity is sufficient for production needs.

The solution to this problem can be wood firewood for heating schools and kindergartens. Also, firewood was and remains the most ecological and economical type of fuel, so there remains the problem of how to facilitate the work of gathering firewood.

2. Analysis of recent research and publications



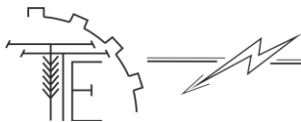

Hydraulic choppers are designed for harvesting firewood in large volumes. The log is automatically directed to the blade and split by the hydraulic cylinder. Hydraulic woodcutters are used in factories and cottages. Can be used for hard wood species. [1-2].

The minimum set of components of the hydraulic system of the simplest hydraulic Shredder includes a hydraulic pump, hydraulic pump drive (engine), hydraulic distributor, hydraulic tank, hydraulic cylinder, hoses and connecting elements.

The shredder for the owners of the house allows you to save a lot, as well as purchase inexpensive logs for their further splitting. Nowadays, wood is the most affordable energy resource. It is especially appreciated if there is no need to hire people to deal with it. There is no need for additional working hands if there is such a home hydraulic Shredder.

The owners of high-quality home splitters are most often the owners of private or country houses where there is no gasification, or those who want to significantly save on expensive blue fuel: [3].

These devices for home use are manufactured with a special hydraulic system. It is designed to move the column quickly and precisely with gradual injection and creation of the necessary effort in order to quickly and evenly split the wood.

Advantages and disadvantages

All hydraulic woodcutters are different:

- + Efficiency.
- + Job security.
- + Simple management.



Fig. 1. A variety of production log splitters for firewood.

Source: grouped by author based on [3]

Despite the advantages, they have disadvantages.

- High price.
- Need to change the oil.
- In case of breakdown, expensive repair of the hydraulic system.

All the advantages and disadvantages of hydraulic systems arise when compared with woodcutters of other types: cone, rail and mechanical.

Cones are unreliable and dangerous. The motor rotates the cone-shaped cleaver. A person directs a log at a cone that is screwed into the wood until it splits. Due to close contact, a cone or a log can injure a person. If the log is directed incorrectly, the woodcutter will break.

In the rail engine, the shaft rotates. The operator lowers the lever, the rail falls on the shaft and it instantly launches it towards the log. The log splits from hitting the ax. The obvious disadvantage is low safety, the log flies to the sides and can catch a person. Therefore, brands of garden equipment rarely produce them.

Mechanical ones are almost always self-made. They only slightly simplify the work compared to the ax.

Advantages of homemade log splitters for firewood:

1. The presence of a special system - hydraulics, which exerts the necessary effort of splitting firewood. Therefore, the equipment knife very quickly and evenly splits a log of any kind, even very hard.

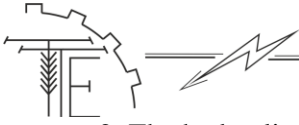

2. The hydraulic household models of the presented Shredders have excellent performance. They are much more efficient than their mechanical counterparts. This factor is especially valuable for busy people who need to harvest a large amount of wood for the house and are serious about professional equipment.

Home Shredder with hydraulics is not equipped with a powerful engine. It has the function of splitting a small area of wood. A shredder divides a log of wood into several parts at once.

3. The purpose of the article

Investigate and prove that the proposed hydraulic wood chipper is effective, speeds up and facilitates work when harvesting wood for ecological and economic heating of both suburban estates and school premises, kindergartens and other industrial buildings.

4. Results of the researches

Project proposed wood chipper.

The hydraulic wood chipper is intended for mechanical chopping of firewood for space heating.

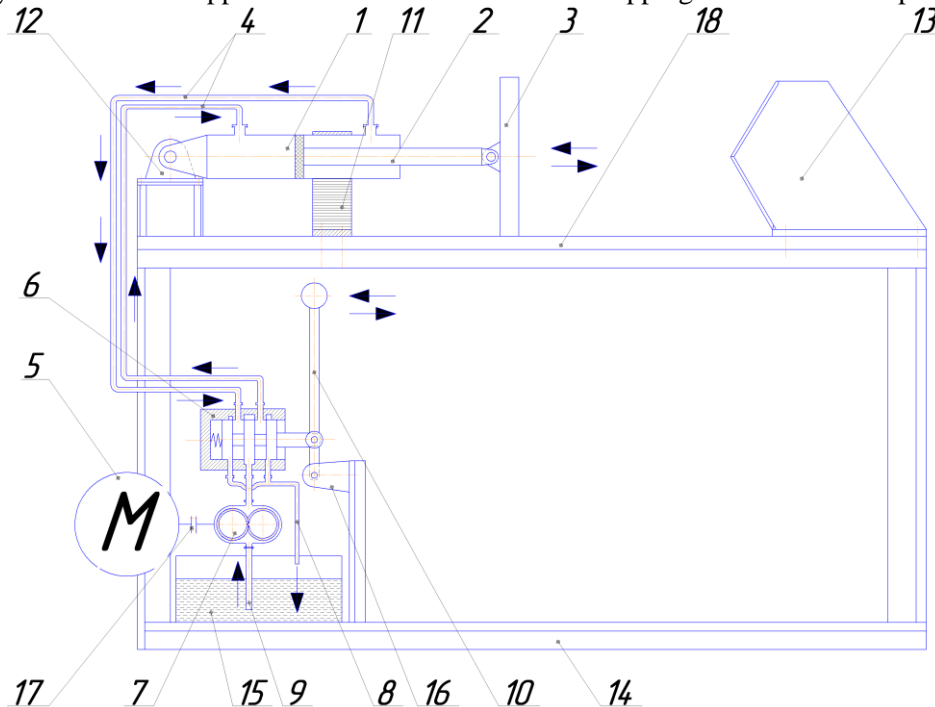

Fig. 2. Structure of the proposed hydraulic shredder:

1 – Hydraulic cylinder; 2 – hydraulic cylinder rod; 3 – pusher; 4 – hydraulic sleeve; 5 – hydraulic pump drive electric motor; 6 – distributor; 7 – hydraulic pump; 8 – oil drain sleeve; 9 – injection sleeve; 10 – lever; 11 – retainer; 12 – hydraulic cylinder mounting bracket; 13 – a knife; 14 – frame; 15 – tank; 16 – lever mounting bracket; 17 – connecting coupling 18 – guide.

The hydraulic Shredder of wood blocks (Figure 2) consists of: a frame 14 on which all the working bodies of the machine are mounted, a hydraulic cylinder 1, connected to the frame 14 through a bracket 12 and a retainer 11, the hydraulic cylinder serves as the executive working body of the Shredder, a pusher 3 is attached to the extendable rod 2, which moves the log to knife 13. Lubricant is pumped through the discharge sleeve 9 to the hydraulic pump 7, then through the distributor 6 it is fed through the sleeves 4 to the hydraulic cylinder 1. The control lever 10 is attached to the frame 14 through the bracket 16. The hydraulic pump 7 is driven by the electric motor 5 through the coupling 17. The oil is poured into tank 15. A guide 18 is attached from the top of the frame, along which the log of wood is guided to the knife 13.

Let's consider the principle of operation of the hydraulic Shredder of wood blocks in figure 3.

The operation of the hydraulic Shredder is very simple: the wooden block 3 is placed on the guide 7 in the place between the rod 2 of the hydraulic cylinder 1 and the knife 4, when oil is supplied to the hydraulic cylinder 1, the rod 2 is pushed forward, thus moving the block 3 to the knife 4, the knife is fixed rigidly to frame and under the pressure of the rod, the pad splits. To select the thickness of firewood, the split log is turned over and the splitting process is repeated.

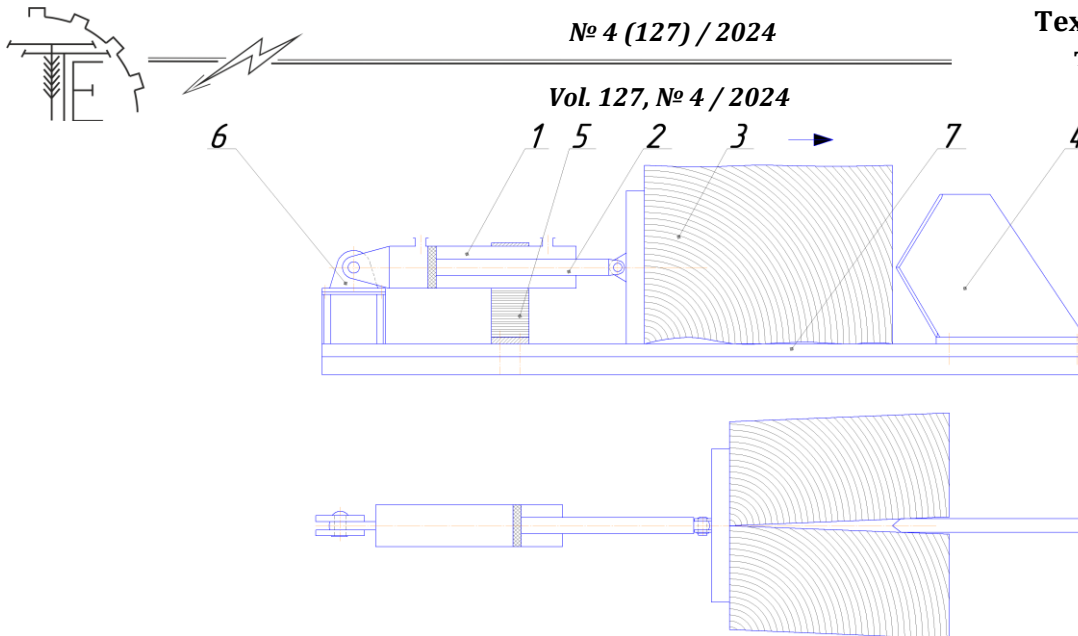

Fig. 3. Operation of the hydraulic Shredder:

1 – Hydraulic cylinder; 2 – hydraulic cylinder rod; 3 – block of wood; 4 – a knife; 5 – retainer; 6 – bracket; 7 – guide.

Wood splitting, as one of its mechanical processing, has become widely used both in industry and in everyday life. To date, a lot of equipment for splitting firewood has been developed, which is diverse in terms of structural features [3]. Despite this, work in the direction of creation of new and improvement of existing structures of cleavers does not stop. This is explained by a significant increase in the price of convenient energy carriers, primarily gas and electricity. This is clearly visible from the diagram in fig. 4, which was built by us based on the analysis of data for the annual heating season presented in [3]. The principle of operation of cleavers depends on the type of knife used in the mechanism and the way it is activated. According to this feature, the following types are distinguished: electromechanical, electrohydraulic and with a rotating screw cone. In mechanical wood splitters, the logs to be split are fed to a stationary knife by a rod, which is driven to translational motion by means of mechanisms for converting rotary motion into translational motion (rail gears or crank-rod mechanism). All electromechanical cleavers have a powerful gearbox with a large gear ratio. The principle of operation of the electro-hydraulic cleaver is as follows: the hydraulic cylinder receives the pressure energy of the working fluid from the electric motor and transfers it to the hydraulic rod, which drives the stop. Hydraulic cylinders create forces on the rod up to 10 tons. Thanks to smooth operation, the blade enters the wooden blank without impact, pierces it, but does not crush it. If the power of the machine is not sufficient to split the log, then the cylinder stops, and the pump continues to work at idle, that is, this mechanism protects the machine from damage. The construction of hydraulic cleavers is simple, and the operational characteristics are high. The main advantage of this type of mechanism is the smooth collision of the log and the knife. A conical or screw-type log splits wood by screwing a steel cone with a screw thread into the side of the log. At the same time, the log is placed vertically, with the bark facing the "conical screw". The design of this cleaver involves the presence of a flywheel with a large moment of inertia, which is installed directly on the shaft of the cone. The rotation of the shaft from the electric motor is carried out using a V-belt transmission. This principle of operation is simpler than in mechanical and hydraulic mechanisms, and therefore is most often taken as the basis for the manufacture of wood-chopping machines with your own hands. This system has several disadvantages - high requirements for engine power, low efficiency due to significant frictional losses and intensive wear of the cutting edge of the tool.

To calculate the costs of heating the room, we will use the formula [4-5]:

$$V = 24QS / (q \cdot 0,01 \cdot \eta), \quad (1)$$

where V – daily energy consumption of the vehicle in m^3 ; Q – heat loss of the building in kW; S – house area in square meters; q – specific calorific value of the energy carrier in kW/cube; η – boiler efficiency.

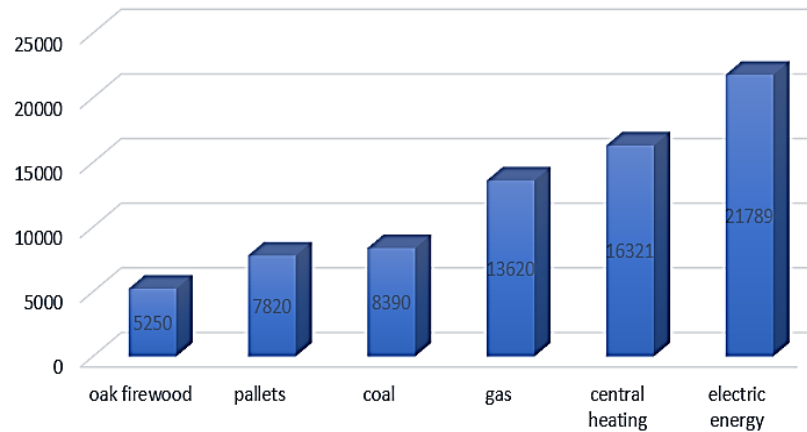
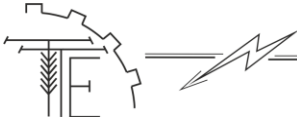

Fig. 4. Chart of costs for heating with different energy carriers per season for an area of 120 square meters

Analytical studies of wood splitting processes are based on the theoretical principles of cutting materials with a wedge-shaped knife, about its rectilinear movement in the direction normal to the cutting edge. At the same time, the anisotropy of wood properties is taken into account. The calculation scheme for modeling wood splitting is presented in Fig. 5. The main input factor in modeling is the geometric shape of the tool, which is described by the function of the wedge angle change $\varphi = f(x)$ (Fig. 5.) as it enters the material. The following indicators of the physical and mechanical properties of wood are taken into account in the model: the adhesion strength of the fibers of the coupling f , the conditional modulus of elasticity during bending, the coefficient of friction on steel.

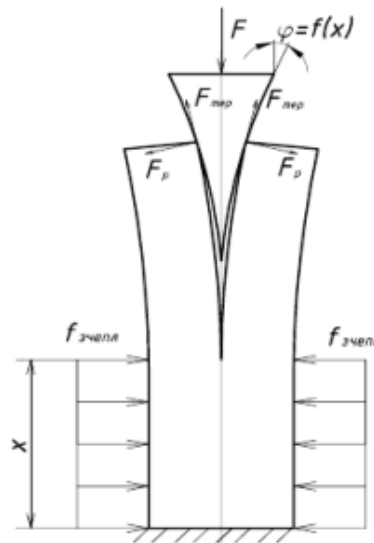

Fig. 5. Calculation scheme of wood splitting

The moments of resistance during bending of log parts in the process of splitting are determined as for a cantilever beam with a section in the form of a segment with a generating angle of 180, 90 and 45 degrees. When the wedge enters the log, the surfaces of its contact with the surfaces formed during splitting are affected by frictional forces $F_{z\text{тер}}$ and forces F_p , which lead to the bending of the formed parts and the further growth of the crack. The initial parameter of the model is the force F (Fig. 5.), which changes when the wedge enters the log. For conducting experimental studies, it is planned to use the PM-5 tearing machine for testing materials, which provides a maximum force of 50000 H. [4-5].

General principle of action

It is not necessary to use an ax - if possible, it will be replaced by a hydraulic Shredder. A good machine can prepare firewood for a week of heating an average house in 3 hours. [6-8].

The proposed Shredder separates firewood without the use of physical force. A person works as an operator: he installs the deck and starts the apparatus. Splitting occurs automatically.

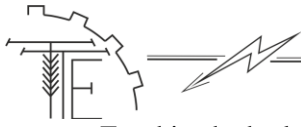

For this, the hydraulic Shredder uses the energy of compressed liquid. It allows you to press the wedge into the log with great effort: creating a pressure of 4-6 tons. How?

The motor starts the pump. The pump pumps oil from the tank to the hydraulic distributor - it regulates the supply of oil to the cylinder and its return to the tank. [9-11].

Having entered the closed space of the cylinder, the oil creates pressure that pushes the rod. In turn, the rod moves the log onto the pick as far as it will go. The pressure increases sharply and is concentrated in one point - on the log. It cannot withstand and gradually splits.

After splitting, a new sleeve of the hydraulic distributor opens and the oil from the cylinder returns to the tank, and the rod returns to its initial position. The pressure normalizes.

If the Shredder cannot handle the log, the safety valve is triggered. It takes some of the oil out of the system to reduce the pressure. If this does not help and the log does not split, the rod is turned back to prevent breakage.

5. Conclusions

Log shredders with a hydraulic system are the best helper for the owner to prepare an alternative source of energy for the heating season. It is easy to operate - you only need to install a deck, press a button or a lever. The log splits smoothly and without human contact, which increases safety. The force of the hydraulic system is enormous, reaching 4-6 tons. The shredder can work with different types of wood and at high speed.

Hydraulic systems are expensive: the price of the simplest household model starts at UAH 5,000. Therefore, the idea arose to independently design a hydraulic log chopper to facilitate the work of harvesting firewood.

The calculations performed, which are shown on the diagram of the costs of heating with various energy carriers (Fig. 4) per season for an area of 120 square meters, indicate that today the most economical and ecological heating is wood. Prices and tariffs may change, but it should be understood that the ratio between prices for different energy carriers (gas-electricity-coal, etc.) almost always remains stable. Prices and tariffs may change, but it should be understood that the ratio of prices for various energy carriers (gas, electricity, coal, etc.) almost always remains stable.

References

1. Kaletnik, H.M., Zdyrko, N.H., Fabiianska, V.Yu. (2018). Biohaz - v domohospodarstvakh - zaporuka enerhonezalezhnosti silskykh terytorii [Biogas - in households - a guarantee of energy independence of rural areas]. *Economy. Finances. Management: topical issues of science and practice*, 8 (36). 7–22. [in Ukrainian].
2. Shvets, L.V. (2020). Proektuvannia tekhnolohichnoi linii dlia vyhotovlennia palyvnykh hranul [Designing a technological line for the production of fuel pellets]. *Vibrations in engineering and technology*, 2 (97), 149–156. [in Ukrainian].
3. Electronic resource. URL: https://arpal.ua/izmelchiteli-vetok?utm_source=google&utm_medium=cpc&utm_term=%D0%B4%D1%80%D0%BE%D0%B2%D0%BE%D1%80%D1%83%D0%B1%D0%BA%D0%B0&utm_campaign=Uk&utm_content=&gad_source=1&gclid=EAIAIQobChMIodOQsrO4iAMVY5doCR2tdBYHEAAYASAAEgJWNvD_BwE (date of application 2024.09.01) [in Ukrainian].
4. Electronic resource. URL: https://er.knutd.edu.ua/bitstream/123456789/11618/1/NRMSE2018_V2_P443-444.pdf (date of application 2024.09.01). [in Ukrainian].
5. Hunko, I.V., Burlaka, S.A. (2022). Otsinka enerhetychnykh pokaznykiv gruntoobrobnoho ahrehatu [Evaluation of the energy indicators of the tillage unit]. *Engineering, Energy, Transport AIC*, 2 (117), 47–52. [in Ukrainian].
6. Veselovska, N.R., Rutkevych, V.S., Sharhorodskyi, S.A. (2019). *Tekhnolohichni osnovy silskohospodarskoho mashynobuduvannia [Technological foundations of agricultural machine building]: Study guide*. Vinnytsia: VNAU. [in Ukrainian].
7. Budiak, R.V., Posviatenko, E.K., Shvets, L.V., Zhuchenko, H.A. (2020). *Konstruktsiini materialy i tekhnolohii [Construction materials and technologies]: Study guide*. Vinnytsia National Agrarian University. [in Ukrainian].
8. Popovych, V., Holubets, V. (2018). *Tekhnolohiia konstruktsiinykh materialiv i materialoznavstvo [Technology of structural materials and materials science]. Book II*. Amounts. [in Ukrainian].
9. Shvets, L.V. (2019). Tekhnolohichni peredumovy vykorystannia bioenerhetychnoho potentsialu sadiv ta zemel lisohospodarskoho pryznachennia [Technological prerequisites for using the bioenergy potential of gardens and forestry lands]. *Vibrations in engineering and technology*, 4 (95), 86–93. [in Ukrainian].

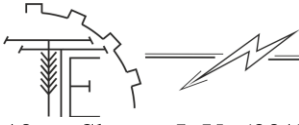

10. Shvets, L.V. (2017) Mashyna dlia rizannia i podribnennia chaharnykyv [A machine for cutting and shredding shrubs]. *Engineering, Energy, Transport AIC*, 2 (97), 153–161. [in Ukrainian].
11. Shvets, L.V., Kucherenko, M.O. (2022). Rozrobka ustanovky dlia vyrobnytstva elektroenerhii ta podachi vody z vitrovym pryvodom [Development of a wind-driven power generation and water supply installation]. *Engineering, Energy, Transport AIC*, 4 (119), 120–129. [in Ukrainian].

РОЗРОБКА ТА ЕФЕКТИВНІСТЬ ВИКОРИСТАННЯ ГІДРАВЛІЧНОГО ПОДРІБНЮВАЧА ДЕРЕВИНИ ЯК ІНСТРУМЕНТУ ДЛЯ ПІДГОТОВКИ АЛЬТЕРНАТИВНОГО ПАЛИВА

Головне питання, яке ставить собі людина, коли у неї виникає необхідність забезпечити теплом свою оселю. В теперішній, військовий час в Україні: як це зробити вигідніше, при нинішньому рівні комфорту? Кожен вибирає сам, виробники енерговиробного обладнання (газових, рідко- або твердопаливних котлів, електричних обігрівальних приладів, сонячних установок, теплових насосів) проводить активну рекламну кампанію, намагаючись довести, що саме його обладнання – найвигідніше та найкраще. Пересічний споживач не маючи відповідного досвіду, зазвичай приймає спонтанне рішення, спираючись у своєму виборі на рекламу чи переконання продавця. Для використання альтернативних паливних ресурсів, а саме деревини, пропонуємо розглянути розробку гідравлічного розколювача деревини, що значно по легше людську працю. .

Найбільш дешевим способом опалення заміського будинку є котел, що працює на твердому паливі (дрова, антрацит). Але слід розуміти, що разом із відносною дешевизною тепла при даному способі опалення виникає низка проблем пов'язаних із зберіганням палива та необхідністю постійного обслуговування котла: його завантаження, розпалювання та чищення. Чи варто заощадити та обладнати свій будинок твердопаливним котлом чи все-таки зупинити свій вибір на газовому котлі (або рідкопаливному, що працює на мазуті), під час роботи з якими весь процес виробництва відбувається повністю автоматично? Вибір за вами. Але у будь-якому випадку, як можна бачити зупиняти свій вибір на електроопаленні, сонячному обладнанні або тепловому насосі без особливих на це причин, мабуть, поки що не варто: ці технології на сьогоднішній день все ще занадто дорогі для широкого використання.

На сьогодні дрова були і є самими екологічним і економічним видом пального. Тому господарі задаються питанням, як полегшити заготівлю дровами, щоб зберегти своє здоров'я.

Подрібнювач колод з гідравлічною системою – найкращий помічник власника для підготовки альтернативного джерела енергії до опалювального сезону. Він простий в експлуатації - потрібно лише встановити колоду, натиснути кнопку або важіль. Колода розділяється плавно і без контакту з працівником, який знаходиться в безпеці. Зусилля гідравлічної системи величезне, досягає 4-6 тон, подрібнювач може працювати з різними породами деревини і на високій швидкості.

Ключові слова: колода, гідравлічний подрібнювач, подрібнювач деревини, твердопаливний котел, альтернативне паливо.

Ф. 1. Рис. 5. Літ. 11.

INFORMATION ABOUT THE AUTHORS

Ludmila SHVETS – Candidate of Technical Sciences, Associate Professor, Department of Agricultural Engineering and Technical Service Vinnytsia National Agrarian University (Sunny str., 3, Vinnytsia, Ukraine, 21008, e-mail: shlv0505@i.ua, <https://orcid.org/0000-0002-4364-0126>).

Oleksandr SHVETS – Recipient of the Second Educational and Qualification Level Vinnytsia National Agrarian University (Sunny str., 3, Vinnytsia, Ukraine, 21008).

ШВЕЦЬ Людмила Василівна – кандидат технічних наук, доцент кафедри агроінженерії і технічного сервісу Вінницького національного аграрного університету (ВНАУ, вул. Сонячна, 3, м. Вінниця, Україна, 21008, e-mail: shlv0505@i.ua, <https://orcid.org/0000-0002-4364-0126>).

ШВЕЦЬ Олександр Ігорович – здобувач другого освітньо-кваліфікаційного рівня магістра з галузевого машинобудування (вул. Сонячна, 3, м. Вінниця, 21008, Україна).