

UDK 631.3.072

THE NOISE MEASUREMENT OF SOME HAND-HOLD FARM MACHINES

D.Irinchev

D.Ziapkov

Agriculture university - Plovdiv, Bulgaria

Ручные, переносные, и малогабаритные сельскохозяйственные машины широко применяются в малых сельскохозяйственных и садово-парковых предприятиях. Однако, при их работе возникают повышенные шумы, оказывающие вредное влияние на здоровье операторов. В статье приведены результаты измерения шума указанных машин и его сравнение с существующими нормативными требованиями.

Introduction

Much of the operations in the farms are made by hand-hold machines, as motocultivators, chain saws, trimmers, hedge shears and others. They allow high productivity, but emit harmful noise. The noise is caused by the engine and the technological operation, [1,2,3,4,5]. There are guiding international standards on the measurement of airborne acoustical noise and evaluation of its effects on human beings, [6,7,8,9].

The aim of the investigation is to indentify the noise value of some hand-hold machines while working. The objective of this paper is to measure the noise of machines of this kind and to compare their date to the standart norms.

The Ministry of Labor and Social Politics and the Ministry of Health have a Regulation №6 at 15 august 2005 Year. This regulates the level at the expositions of noise by working with machines, they are able to harm the health of the workers. The day-level of exposition of noise and the pick of noise pressure are definite:

1. The limited values of exposition are - 87 dB(A) and p_{peak} 200 Pa, according 140 dB(C).
2. The high value of exposition to undertake an activity are - 85 dB(A) and p_{peak} 140 Pa, according 137 dB(C).
3. The low value of exposition to undertake an activity are - 80 dB(A) and p_{peak} 112 Pa, according 135 dB(C)

The level of sound pressure by A (dB) is a sound pressure, defined by corrected sound characteristics of the humans ear.

Material and Methods

Researched hand-hold farm machines, [10,11,12,13]:

1. Motocultivator MK-9S.

Engine – Subaru Robin, power 6,6 kW, mode four stroke, petrol, 1-cilinder.

Height – 1120 mm.

Width – 595 mm.

Length – 2050 mm.

2. Chain saw – Stihl ST MS250.

Engine two stroke 2 MIX, cc - 45,4 cm³, power – 2,3 kW, weight - 4,6 kg, length – 40 cm.

Sound level – 99,0 dB(A) and sound power – 111 dB(A), K-factor – according to Directive 2006/42/EO=2,5 dB(A).

3. Trimmer Husqvarna – 128 LDx.

Weight – 4,9 kg, length – 1320 mm.

Engine – two stroke, petrol, cc - 28 cm³, power - 0,8 kW, nominal speed – 8000 min⁻¹, max speed – 10000 min⁻¹, idle - 2700 min⁻¹.

Sound level – 94 dB (A), guarantee sound level - 114 dB (A), K-factor in accordance with Directive 2006/42/EO=2,5 dB(A).

4. Hedge shear - STIHL HSB1T.

Weight – 5,4 kg, length – 75 cm, engine – two stroke petrol, cc - 22,7 cm³, power – 0,7 kW.

Sound level – 94,0 dB (A) and sound power - 104,0 dB (A), K-factor in accordance with 2006/42/EO=2,5 dB(A).

The sound power levels of noise sources are determined using sound pressure $p(t)$.

Survey acoustical method uses a reference sound source. The support sound pressure p_0 is 20 μ Pa. The used equation for calculation of day-sound level of noise L_{pA} is:

$$L_{pA} = 10 \lg \left[\frac{1}{T} \int_0^T \frac{p^2(t)}{p_0^2} dt \right], \text{ dB} \quad (1)$$

where T is the work time.

The day level of exposition of noise by inconstant noise L_E is calculated by:

$$L_E = L_{pA} + 10 \lg \frac{T_E}{T_0}, \text{ dB} \quad (2)$$

where T_E is the day exposition of noise, h;

T_0 – the day work time, 8 h.

The level of sound power L_W is calculated:

$$L_W = L_{Af} + 10 \lg \frac{S}{S_0}, \text{ dB} \quad (3)$$

where S is the surface of measurement;

$S_0 = 1 \text{ m}^2$;

L_{Af} - A-level of sound pressure of the surface.

Technical standard BDS EN-709 treats the verification of noise emission values of machinery and equipment. For motocultivator MK-9S is utilized sound levelmeter Puls 3560 C2510726 – producer B&K, microphone B&K 4188-A-2.

According to Technical standards BDS EN-1553, Technical standards BDS EN-11201 and Amendment 1:1993 EC 804:1985 Integrating-averaging sound level meters, and Amendment 1:1989, and Amendment 2:1993, sound level meter is CASELLA type CEL 244, sound calibrator RFT 05000.

The situation of microphon by measuremen the noise of motocultivator MK-9S is shown at fig.1.

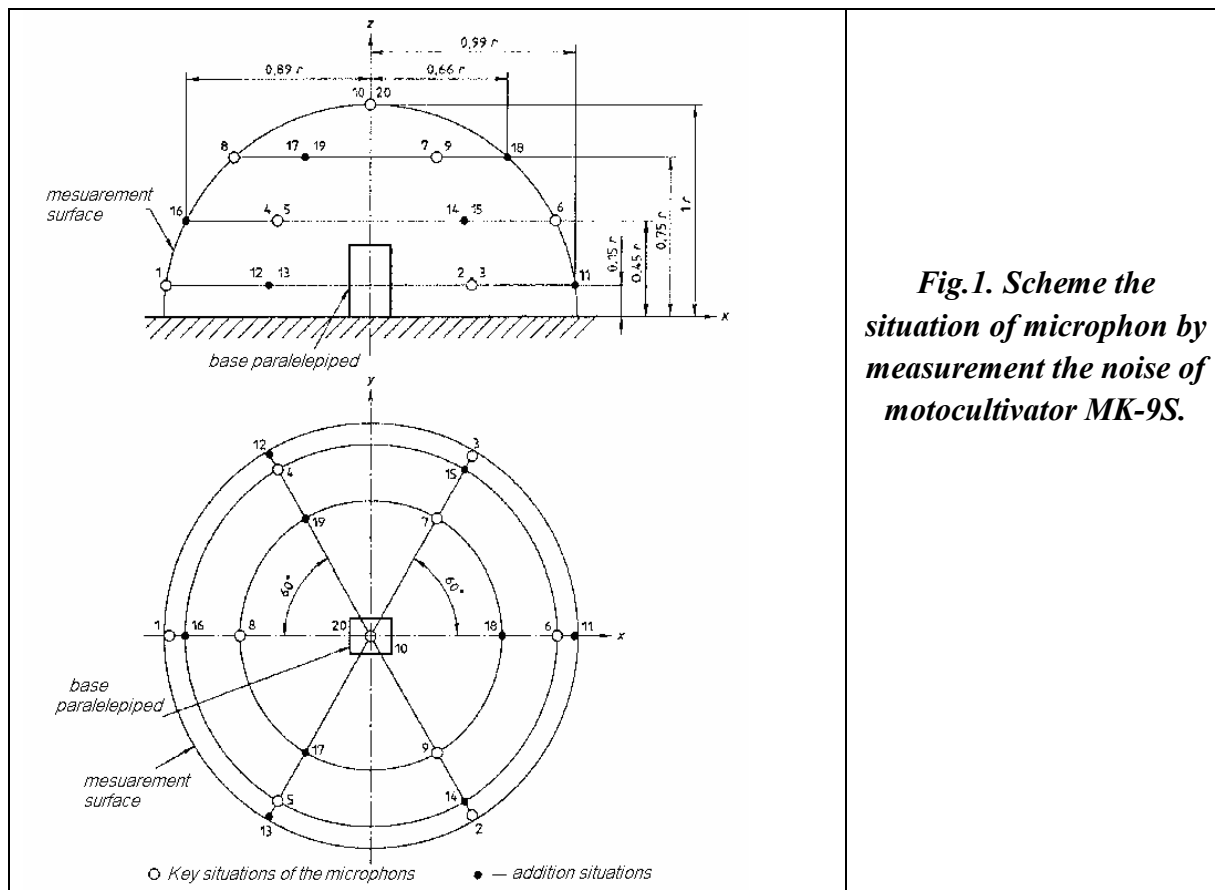

Fig.1. Scheme the situation of microphone by measurement the noise of motocultivator MK-9S.

These engineering methods are designed for certification of production attitude of the emission noise. They are used for a measurement of the level of the noise in exploitation circumstances.

and discussion

The circumstances of the experiment and measured data are shown at **Tabl.1** and **Tabl.2**.

Tabl.1.

Results of measurement the motocultivators MK-9S noise

	Parameter	measured, dB
1.	A-level of sound pressure at working place*	
	measurement 1, 2, 3	79,95
2.	A- level of sound pressure	
	Microphone position 1	77,47
	Microphone position 3	76,03
	Microphone position 5	75,65
	Microphone position 7	77,78
3.	A-level of sound pressure of the surface	
	mesuarement 1, 2, 3	76,23
4.	A- level of sound power	
	measurement 1,2,3	96,25

* - by 3 measurements.

Tabl.2.

Experimental date of noise at work with farm machines

Farm machine	Operation	Equivalent level of noise, dBA	Peak level of sound pressure, dBC	Measured day-level of exposition the noise, dBA *
Chain saw STIHL ST MS 250	Cutting of branch	96	99	87
	Idle	76	76	-
Hedge shear STIHL ST HSB1T	Forming the bushes	96	99	87
	Idle	76	78	-
Trimmer Husqvarna	Cutting lower grass	92,5	92,5	83,5
	Idle	77	80	-

* - the calculation is made by time of influence 1 hour.

** - the idle rate is by minimal rotated speed of the engine.

The noise during operation with chain saw, hedge shear and trimmer is measured close to workers ears.

The analysis of the levels of the sound pressures of the motocultivators MK-9S shows that, the middle value, near the worker is 3,72 dB over than that one measured at the surface – 4m from machine.

The calculated value sound power L_W is 20 dB bigger than the value sound pressure L_{Af} at measurement surface.

Analysis of data in Tabl.2 indicate, that by idle rate the equivalent noise value L_{pA} for three investigated machines is about 20 dB lower than these by working rate. The high level sound pressure of chain saw and hedge shear is 3 dB higher than equivalent level.

By working time T_E – the calculated day-level of exposition L_E – for the three machines – is 9 dB lower than equivalent levels.

Conclusion

1. The investigation comes to the conclusion that, the equivalent value of noise during examined hand-held farm machines is lower than announced value in technical characteristics, and the peak level of sound pressure is near to announced value.

2. The day exposition of noise is lower than these within the limits of norms - 87 dBA according to Regulation №6, [9].

3. The level of the noise by experimental farm operations with hand-held and small machines is the reason for the undertaking some precautions, for example using antifones.

References

1. Characteristics of annual exposure to noise among private farmers on family farms of mixed production profile, *Annals of agricultural and environmental medicine*, vol.13, issue 1, 2006.

2. Dewangan K.N., *Noise characteristics of tractors and health effect on farmers, Applied Acoustics, Vol.66, Issue 9, Sept. 2005.*
3. Evans J.R., *Practical solutions to noise problems in agriculture, Silsoe Research Institute and RMS Vibration Test Laboratory for the Health and safety Executive, Research Report 212, 2004.*
4. Peng C., *Noise propagation in the Agricultural Environment, Silsoe Research Institute, Journal of Agricultural Engineering Research, Volume 60, Issue 3, March 1995.*
5. *Survey of the working condition of used tractors in northern Italy, J. Agric. Engin. Research, Vol. 62, issue 3, 1995.*
6. *Technical standards BDS EN-70. Verification of noise emission values of machinery and equipment. IEC 942:1988. Sound calibrators.*
7. *Technical standards BDS EN-1553. Sound level meters, and Amendment 1:1993. EC 804:1985. Integrating-averaging sound level meters, and Amendment 1:1989, and Amendment 2:1993.*
8. *Technical standards BDS EN ISO 11201.*
9. *Министерство на труда и социалната политика на Република България, Министерство на здравеопазването, Наредба №6. The Ministry of labor and social politic and the Ministry of health in Republic Bulgaria.*
10. *Technical specification of Motocultivator MK-9S.*
11. *Technical specification of hedge shear STIHL ST HSB1T.*
12. *Technical specification of chain saw STHL ST MS 250.*
13. *Technical specification of trimmer Husqvarna.*